

PENNSYLVANIA  
VEGETABLE GROWERS

# NEWS



November 2022 / Volume 45 Number 11

for the commercial vegetable, potato and berry grower



**2023**  
**MID-ATLANTIC**  
*fruit & vegetable convention*  
JANUARY 31–FEBRUARY 2, 2023  
HERSHEY LODGE  
Hershey, Pennsylvania  
[www.mafvc.org](http://www.mafvc.org)

## Pre-Convention Workshops – January 30



- Adams County Bus Tour
- Greenhouse Vegetable School
- Starting & Improving Your Farm Transition Plan
- Fruit Tree Pruning
- FSMA Grower Training
- Spotted Lanternfly Permit Training
- PA Pesticide Applicator License Training
- Managing A Profitable Farm Market Bakery



## Plan Now to Attend this Year's Convention!

The 2023 Mid-Atlantic Fruit and Vegetable Convention will be held in-person at the Hershey Lodge on January 31 to February 2, 2023. Michael Kilpatrick from Growing Farmers will be this year's keynote speaker. An Adams County bus tour and several pre-convention workshops will be offered on January 30, 2023.

Normally over 2,200 fruit, vegetable, and berry growers and other industry personnel from throughout the mid-Atlantic region and beyond gather in Hershey each year for what has become one of the premier grower meetings on the East Coast. This will be the 46th annual edition of the Mid-Atlantic Convention at the Hershey Lodge in Hershey, Pennsylvania.

Plans are being made to offer exceptional educational sessions on a full-range of topics in tree fruit, vegetable, small fruit, and potato production plus retail and wholesale marketing. Greenhouse ornamental and cut flower sessions will also be offered along with a special session presented in Spanish for Span-

ish-speaking industry members.

The day before the main Convention opens, growers can choose between a bus tour of agricultural businesses in Adams County or several different workshops. The workshops include FSMA Grower Training, Greenhouse Vegetable School, Fruit Tree Pruning, Starting and Improving Your Farm Transition Plan, Managing a Profitable Farm Market Bakery and Pennsylvania Pesticide Applicator License Training. The Mid-Atlantic Convention has been jointly sponsored by the State Horticultural Association of Pennsylvania, the Pennsylvania Vegetable Growers Association, the Maryland State Horticultural Society and the New Jersey State Horticultural Society for the past 45 years. In 2014, the Virginia State Horticultural Society also began meeting at the Convention. The Pennsylvania State University, University of Maryland, Rutgers University Cooperative Extension and Virginia Tech University all assist in organizing the three days of educational sessions.

Continued on page 7

## NEWS



*Pennsylvania  
Vegetable Growers  
Association*

*An association of  
commercial vegetable,  
potato and berry growers.*

*President*

**Rita Resick '23**  
*Somerset*

*First Vice President*

**Peter Flynn '24**  
*West Chester*

*Second Vice President*

**Tina Forry '25**  
*Palmyra*

*Secretary-Treasurer*

**William Reynolds '25**  
*Waynesboro*

*Past President*

**Brian Campbell '24**  
*Berwick*

*Directors*

**Christopher Harner '23**  
*State College*

**Barron Hetherington '25**  
*Ringtown*

**Alan Kemmerer '25**  
*Berwick*

**Arthur King '24**  
*Valencia*

**Amy Metrick '24**  
*Butler*

**Michael Orzolek '24**  
*State College*

**Christopher Powell '23**  
*Strasburg*

**John Shenk '23**  
*Lititz*

**Robert Shenot '25**  
*Wexford*

**Jeffrey Stoltzfus '23**  
*Atglen*

**Jonathan Strite '25**  
*Harrisburg*

**Mark Troyer '24**  
*Waterford*

**Joel Weaver '23**  
*Windber*

*Executive Director*

**William Troxell**  
*Richfield*

## PVGA Annual Meeting

The Annual Meeting of the General Membership of the Association will be held on February 1, 2023, at 11:30 a.m. in the Crystal Room of the Hershey Lodge in Hershey, Pennsylvania. Members will receive reports from the officers and various committees as well as the announcement of the results from the mail-in ballots for the Board of Directors. They will also vote on additions to the Association's Policy Resolutions which state PVGA's position on various issues of the day. All members are urged to attend this meeting.

## We Need Your Help at the Farm Show!

Each year over 200 PVGA members and friends volunteer at the PVGA Food Booth at the Pennsylvania Farm Show in Harrisburg. We need at least 20 or more volunteers in the booth at all the times. Since the Farm Show runs from 8:00 a.m. to 9:00 p.m., we need two shifts to completely cover each day from January 7 to 14, 2023. That translates into a lot of volunteer hours. Plus, we will again be open the afternoon of the previous Friday, January 6, from noon to 9:00 p.m.

You say you don't come to the Farm Show? Why not break tradition and come for once? It's worth the trip just to volunteer your time to the Association and any farmer is bound to see at least a few things of interest at the Farm Show. There is a wide array of exhibits throughout the Complex. Are you really too busy in the middle of the winter to take a day off to help support vegetable and small fruit research? In 2022 we earned about a profit of about \$39,000. The Farm Show Booth profits have helped enable the Association to contribute \$1.4 million to research over the past 34 years.

We are grateful to the many PVGA members who help out each year but we need new volunteers each year. If YOU have never helped before, PLEASE call us today at 717-694-3596 and volunteer for 2023. You'll be helping your Association besides having an enjoyable time.

## PVGA Young Grower Award Applications Being Accepted

The "PVGA Young Grower" award was a new award established four years ago. The winner is chosen each year by the PVGA Leadership and Recognition Committee. PVGA members are asked to nominate a young grower (someone they know or themselves) who meets the criteria for the Award. The criteria are as follows:

- is a PVGA Member who is 35 years old or younger;
- is successfully growing vegetables, potatoes or berries; and
- has contributed to advancing or promoting the Pennsylvania vegetable, potato or berry industry.

The prize for the winner will be free registration and lodging for the 2023 Mid-Atlantic Fruit and Vegetable Convention. To nominate someone or yourself, send a brief but comprehensive description of the farm operation and the nominee's qualifications to PVGA at [pvga@pvga.org](mailto:pvga@pvga.org) or 815 Middle Road, Richfield, PA 17086, by December 31, 2022.

*The Pennsylvania Vegetable Growers News is the official monthly publication of the  
Pennsylvania Vegetable Growers Association, Inc.,*

*815 Middle Road, Richfield, PA 17086-9205*

*Phone and fax: 717-694-3596 • Email: [pvga@pvga.org](mailto:pvga@pvga.org) • Website: [www.pvga.org](http://www.pvga.org)*

### **Our Mission:**

*The Pennsylvania Vegetable Growers Association serves Pennsylvania's commercial vegetable, potato and berry growers through education, research, advocacy and promotion.*

### **Our Vision:**

*The Pennsylvania Vegetable Growers Association will be the driving force in ensuring the future viability of the commercial vegetable, potato and berry industries in Pennsylvania.*

*Inquiries about membership, this publication or advertising rates should be directed to  
William Troxell, Executive Director, at the above address.*

## NEWS



## PVGA Membership - A Bargain Too Good to Pass Up!

Nearly 2,900 people who are not members of PVGA will be receiving this Special Convention Issue of the Pennsylvania Vegetable Growers News compliments of PVGA. We want you to join our Association. We're putting our best foot forward by inviting you to the 2023 Mid-Atlantic Fruit and Vegetable Convention and by giving you the opportunity to see a copy of our monthly newsletter. Together they represent the key educational opportunities the Association offers to its members. And member education is one of the primary missions of the Association.

We believe one of the best ways to see the vegetable, potato and berries industries of Pennsylvania prosper is to have growers who are knowledgeable and up-to-date in their production and marketing practices. Therefore, we have worked hard to offer one of the most comprehensive educational programs for growers on the East Coast at the Mid-Atlantic Fruit and Vegetable Convention. In addition, each month the **Pennsylvania Vegetable Growers News** provides PVGA members with valuable information on current issues affecting growers as well practical production information from experts at Penn State and other universities. Each week, members with email receive the **PVGA Update** with links to news and event announcements online. PVGA also usually sponsors local grower twilight meetings and farm market tours to allow growers to visit fellow growers' farms and markets in person during the growing season – although only a few were able to be conducted this year due to the pandemic.

A \$70 annual membership in PVGA brings you the monthly newsletter as well as subscriptions to the American Vegetable Grower magazine and the Vegetable Growers News. That's a hard bargain to beat but, wait, there's more!!!

Through the efforts of PVGA volunteers at the Association's booth at the Farm Show and from profits from the Convention, the Association is usually able to contribute \$55 to \$70 or more per member to vegetable and small fruit research. Even during 2021, when Association income was about half of the normal amount, PVGA was able to contribute \$80 per member using General Fund reserves that had been built up over the years cover such an unexpected drop in income. We are proud to be able to help our industry stay on the cutting-edge of technology. Over the past 34 years, PVGA has given over \$1.4 million to research.

PVGA is the organized voice of the vegetable, potato and berry industries in the Commonwealth and works to represent your interests in Harrisburg and Washington. Consequently, when legislation that affects the industry is considered, the industry has an organized voice ready to protect your interests.

PVGA owns the trademark for the "Pennsylvania Simply Sweet" onion to provide Pennsylvania growers with the opportunity to market a branded crop at a premium price.

You, if you are involved in the vegetable, potato or berry industries in Pennsylvania (or nearby states), can be a part of the PVGA team by joining today. Until February 5, dues are only \$70 – a real bargain. Use the form on page 27 to join PVGA for 2023.

**If you are currently a PVGA member, it is especially important to renew your membership for 2023.**

## NEWS

## Program Promotes PA Veggies to Millions in 2022



The Pennsylvania Vegetable Marketing and Research Program once again actively promoted PA Veggies reaching millions of Pennsylvania consumers. The Program introduced the theme “Summer Means Local! Local Means Delicious”. Plus, this was be the 17th year that the Program promoted the bountiful supply of Pennsylvania vegetables available in August with the PA Produce Month promotion. However, as the “Summer Means Local” theme implies, the Program expanded its promotion efforts to include July and September – before and after Produce Month.

Press releases, social media posts, consumer emails, blogs, and new website content were all used to promote PA Produce for this season. With the help of a Specialty Crop Block Grant (SCBG), the Program once again worked with Taste Profit Marketing, to tout Pennsylvania vegetables in 2022.

A new initiative for 2022 is to use some of the SCBG funds to do paid advertising on social media. The Program has been using social media – Facebook and Instagram – for several years with good results. By using paid advertising on these social media outlets, the Program hoped to significantly increase the number

of people being reached with these posts which in turn link to the many consumer resources available on the website. These ads were seen by nearly 2 million individuals in Pennsylvania and resulted in 21,000 people visiting the [www.paveggies.org](http://www.paveggies.org) website. Recipes and how-to-use videos on the website were viewed at least 42,875 times. The grower directories on the website were accessed at least 680 times.

The Program worked with social media content creators to create two videos promoting PA veggies that were viewed by over 30,000 people on Instagram. Two video ads on TikTok were watched to completion by 2,686 viewers.

The Program sent out a series of monthly emails during the summer to its list of consumers and worked to increase the number of consumers on the list. Growers (for whom the Program had email addresses) also received a series of emails outlining the Program’s marketing resources available to them.

The Program distributed 120 PA Produce Month point-of-purchase kits to the produce auctions for sale to their buyers and to over 200 supermarkets who requested them.

## Marketing and Research Board Meets

The Pennsylvania Vegetable Marketing and Research Program Board met on November 7 to elect officers for 2022, to meet with researchers to review research pre-proposals, and to discuss promotion plans for 2023.

The Board, made up of 12 growers appointed by the PA Secretary of Agriculture, a sales agent representative and a representative of the Secretary, re-elected its current officers which are Christopher Powell of Strasburg as the Chair, Scott Hoffman of Northumberland as the Vice Chair and Kenneth Metrick of Butler as the Secretary-Treasurer.

The Board, along with some representatives from PVGA on the joint Vegetable Research Committee, reviewed 13 research pre-proposals with researchers who attended the meeting virtually. They then determined which pre-proposals they were most interested in seeing full-proposals for at their February 1 meeting.

They also reviewed the promotion activities of the past year,

again with some representatives of PVGA on the joint Vegetable Marketing Committee. Zoe Scheaffer, from the Board’s marketing consultant Taste Profit Marketing, then reviewed the plans for 2023 under the Specialty Crop Block Grant (SCBG) project which the Program was awarded that will support continued digital advertising, social media campaigns and other activities in 2023.

The Board extended the contract for administrative services with Troxell Administrative Services for 2023. Finally, they adopted a tentative 2023 budget that anticipates \$188,550 in income and \$197,750 in expenses. It anticipates \$30,000 in research contributions from PVGA and allocates an additional \$26,000 from growers’ assessments for a total of \$56,000 for research. It also provides \$106,050 for vegetable promotion including \$81,450 for the SCBG project. The Program will be also be receiving a \$5,000 matching grant from the state Department of Agriculture.



# PLANT. PICK. PROFIT.

BETTER GENETICS. BETTER PRODUCTIVITY.  
BETTER PROFITABILITY.



**LUNAR**

### 56 Day Fresh Market Bush Bean

This SEEDWAY EXCLUSIVE has strong seed quality. Excellent plant habit for easier harvest. Does well in hot growing conditions. Uniform, dark green pods (3-4 sieve).

HR: BCMV, CI  
IR: Ua



**BEACON**

### 70 Day Sweet Banana Pepper

This sweet banana pepper combines excellent disease resistance with great early yield of straight, heavy, thick walled fruit. It is great for processing. HR: Xcv 1 - 3, TSWV



**AUTUMN PEARL**

### 95 Day Pie Pumpkin

Pie pumpkins are a favorite everywhere! Autumn Pearl makes its introduction into the pie pumpkin class with an all around eye catching appearance: sturdy handle, distinct ribbing and dark orange color. One to try for 100-110 count bins (24" bins). Recommended spacing is 15 to 18 square feet per plant. IR: Sf



**LAZOR**

### 42 Day Yellow Straightneck Summer Squash

Exceptionally firm, smooth fruit alleviates some of the "roughness" typical of first picks. Thick and sturdy neck promotes easy handling. Attractive glossy skin. IR: ZYMV

(800) 952-7333

[www.seedway.com](http://www.seedway.com)

## NEWS

## Gugino Named Assistant Dean



Beth Gugino, professor of plant pathology in Penn State's College of Agricultural Sciences, has been named assistant dean for graduate education in the college. Her appointment was effective Oct. 1.

Reporting to the associate dean for research and graduate education, Gugino will provide administrative and programmatic leadership for 13 resident and three online graduate degree programs, as well as for the college's participation in nine inter-college graduate degree programs. She also will develop and implement programs that enhance graduate student success, promote research experience and guide professional development to support the research mission of the college.

"Beth Gugino's experience as a researcher, graduate program coordinator, student mentor and extension specialist gives her a comprehensive understanding of the college's land-grant mission," said Blair Siegfried, associate dean for research and graduate education. "Her innovative ideas and her commitment to training and mentoring our graduate students to become contributing members of the scientific community will be invaluable in attracting the best and brightest graduate researchers to the college."

Gugino noted that she looks forward to building on the strengths of the college's current graduate programs.

"I plan to seek opportunities to enhance graduate education so that our graduates have not only the knowledge and skills to conduct top-notch research and extension programming but also the essential skills needed to navigate and succeed in a diverse and competitive job market," she said. "In addition, my hope is to communicate the value of a graduate degree from the College of Agricultural Sciences as we work together to recruit and build a graduate student community that is diverse and resilient."

Gugino earned a bachelor's degree in horticulture and master's and doctoral degrees in plant pathology, all from Penn State. She was a postdoctoral scholar in plant pathology at Cornell University from 2004 to 2008 before joining the faculty in Penn

State's Department of Plant Pathology and Environmental Microbiology as an assistant professor.

She achieved the ranks of associate professor in 2014 and full professor in 2019. She also has been director of graduate studies for the department since 2016.

Gugino has been thesis or dissertation adviser or co-adviser for 12 graduate students and has served on the graduate committees of more than 30 others. She also has contributed to courses in integrated pest management and has mentored nine undergraduates during independent research or internships.

Gugino's research and extension interests include integrated vegetable disease management, plant pathogen diagnosis, disease monitoring and forecasting, and sustainable crop production. She works with research faculty, extension specialists and county-based educators to develop integrated pest and crop management strategies to address important and emerging diseases of the major vegetable crops grown in Pennsylvania.

She also has focused on existing and new technologies that can provide growers and other agricultural service providers with research-based information on pathogen biology, epidemiology and vegetable disease management. She has authored or co-authored 37 peer-reviewed journal articles, 80 conference proceedings and scores of extension publications and trade journal articles. In addition, she has given more than 350 extension presentations.

Gugino has served on several college and University committees and is a member of the American Phytopathological Society, the Pennsylvania Association for Sustainable Agriculture and the Pennsylvania Vegetable Growers Association. She served on the board of directors of Pennsylvania Certified Organic from 2017 to 2021, and she is currently a member of the Pennsylvania Department of Agriculture Pesticide Advisory Board.

Among Gugino's numerous awards and honors are the 2019 American Phytopathological Society Excellence in Extension Award, the 2013-14 Department of Plant Pathology and Environmental Microbiology Excellence in Teaching Award, and the 2011 American Phytopathological Society Northeastern Division Early Career Professional Award. She was inducted into Gamma Sigma Delta - Honor Society of Agriculture and Phi Alpha Xi - Honor Society of Horticulture.

**SEE VIDEOS OF SPRAYERS IN ACTION ON UPDATED WEBSITE!  
NEW HYDRAULIC FOLD SPRAYER FEATURES  
AIRBAG BOOM SUSPENSION!**



**200, 300 & 400 Gal. Manual Fold • 300 & 400 Gal. Hyd. Fold**

*Ask us about the advantages of the front mount boom.*

**PENNS CREEK MFG.**

1340 Broadway Rd., Winfield, PA 17889

570-837-1197

[www.pennscreekwelding.com](http://www.pennscreekwelding.com)

**BUILDERS OF DEPENDABLE ECONOMICAL VEGETABLE SPRAYERS**

**CONVENTION**

**2023 Mid-Atlantic Convention** *continued from page 1*



**Keynote Speaker**

Michael Kilpatrick is a farmer, presenter, host, inventor, and online entrepreneur who lives to help entrepreneurs apply business principles and practical, proven solutions to grow their businesses and simplify their lives. He is the owner of Growing Farmers, an online farmer education platform; host of the top-rated Thriving Farmer Podcast; and host of the Thriving Farmer Summit series, which has been viewed by over a quarter million farmers. He has managed large farms and

businesses, consulted for industry experts worldwide, and spoken at dozens of conferences. Michael believes anyone can build a profitable farm by following the proprietary RIPEN system that he teaches in the Small Farm University, his company's educational platform and community for thriving farmers. Michael lives in an 1890s brick house on his 8-acre urban *Farm on Central* in Southwest Ohio with his wife and 3 kids. His keynote topic will be "Thriving in Uncertain Times".

The Convention has become one of the premier grower meetings in the Northeast. The Great American Hall and the Aztec Room at the Hershey Lodge will host most of the Trade Show with several additional booths being located in the Confection Level Lobby. Specialized horticultural equipment, farm market merchandise, and packaging will all be on display along with information on the latest seed varieties, fruit varieties, pesticides and other supplies and services for the commercial grower.

Many pesticide applicator update training credits will be available to Pennsylvania, Maryland, New Jersey and Virginia growers attending the sessions. The program covers nearly every aspect of fruit, vegetable, potato and berry production. Commercial growers should not pass up this terrific educational opportunity.

The sixteenth annual Mid-Atlantic Cider Contest will be conducted during the Convention to determine the best tasting cider produced in the region. On January 31, fruit and vegetable growers will gather for the annual Fruit and Vegetable Growers Banquet which will include awards and recognitions. On February 1, there will be an Ice Cream Social for all in the evening plus a reception for apple growers.

*Continued on page 8*

**ProducePackaging.com®**

*for all your produce packaging needs*

**1-800-644-8729**

**Kurt Zuhlke & Assoc., Inc.**  
P.O. Box 609, Bangor, PA 18013



*Over 45 Years In The Industry*

For over 45 years, Kurt Zuhlke & Assoc., Inc. has been a part of the many innovative packaging concepts utilized by the produce industry.



*High Quality Products And Services*

Our packaging is designed to protect produce, provide excellent visibility to the consumer, reduce shrinkage and enhance the product. We also offer professional labeling design and application.



*From Farmers To Repackers*

Whether you are ordering a case or a truck load, you can rest assured that we have the ability and capacity to service your orders quickly.



## CONVENTION

### 2023 Mid-Atlantic Convention *continued from page 1*

Registration is required for all persons attending the Convention trade show or educational sessions. Registration with any of the five sponsoring organizations allows one to attend any of the sessions although there are additional charges for workshops and meals.

The Convention is not all business. It is a wonderful opportunity to take a short vacation in Chocolatetown, USA, "The Sweetest Place on Earth," with fellow vegetable and fruit growers.

The Hershey Lodge is the ideal place for you to be January 31 to February 2, 2023. Take advantage of the special reduced room rate of \$166 (plus 11% taxes) in effect for the Convention. To make a room reservation, call 1-855-729-3108 and ask for the Mid-Atlantic Fruit and Vegetable Convention block or go the "Lodging" page on the Convention website at [www.mafvc.org](http://www.mafvc.org). **Be sure to make your reservation as soon as possible to guarantee receiving the discounted rate.**

Whether you stay overnight or not, it will be well worth your while to drive to Hershey, even if you just stay for the day. Pennsylvania growers need to be informed about the newest and best in their industry and most of us could use some reminding about the basics or some fresh inspiration from the success of others – or lessons from their failures!

The 2023 Convention program continues our standard of a world-class grower educational meeting. So do yourself a favor and make a sound investment in your business by attending the 2023 Mid-Atlantic Convention.

Please let us know about your plans. Advance registration can save you money and exempt you from waiting in a registration line.

We hope to see you in Hershey. If you can't make to Hershey, you can still order a copy of the Proceedings so you won't miss out on the educational opportunities of the Convention.

#### Convention Lodging

Plan to stay at the Hershey Lodge and take advantage of the special convention rate of \$166 (per room per night plus taxes). Call the Lodge at 1-855-729-3108 and tell them you are attending the Mid-Atlantic Fruit and Vegetable Convention. Or you can make reservations online at [www.mafvc.org/Lodging](http://www.mafvc.org/Lodging).

#### Convention Proceedings

If you cannot attend the Convention, you can purchase a copy of the Proceedings which contains summaries of many of the vegetable, small fruit, greenhouse and marketing presentations. Use the form on page 34.

### TEW MANUFACTURING CORP.

**Fruit & Vegetable Cleaning & Sizing Equipment & Parts**

**Quality Latex & Poly Sponge Rubber Drying Donuts**

**Tuff Foam® Protective Padding**

**Brushes • Bearings • Sizing Chains**

**Belting • Scrubber Rubber**

**New Stainless Steel Machines**

**CALL TOLL FREE 800-380-5839**  
**FOR CATALOG & PRICES**

TEW MFG. CORP.  
P.O. BOX 87  
PENFIELD, NY 14526

585-586-6120  
FAX: 585-586-6083  
[www.tewmfg.com](http://www.tewmfg.com)

Your Source for . . .

# HIGH TUNNELS



Call Harry Edwards @ 717.606.8021  
or Email [hedwards@rimol.com](mailto:hedwards@rimol.com)



**Southern Container Corporation of Wilson, NC**

6003 Ward Blvd., Wilson, NC 27893  
Website: [www.socontainers.com](http://www.socontainers.com)

Harry Helmer - 252-230-4958 - [hhelmer@socontainers.com](mailto:hhelmer@socontainers.com)  
Chris Thompson - 252-230-1376 - [cthompson@socontainers.com](mailto:cthompson@socontainers.com)  
Don Nichols - 252-668-0418 - [dnichols@socontainers.com](mailto:dnichols@socontainers.com)

**Serving the Tobacco & Produce Industries For Over 60 Years**

# Agricultural Packaging Solutions

## SHIPPING TRAYS & PRODUCE BOXES



8 - 1 Quart

12 - 1 Pint

6 - 1 Quart

12 - 1 Pint Quick Pop

8 - 1 Pound

4 - 1 Quart



10# Sweet Potato Boxes

20# Sweet Potato Boxes

40# Sweet Potato Boxes

Plastic Corrugated Corn and Cabbage Boxes



Produce Bins - 18" - 42"  
Plain, Watermelon, and Pumpkin Print Available

Waxed, Green Coat, & Dry Produce Boxes, Various Sizes

10 & 25 Pound Tomato Box

24 Qt. Potato/Tomato Picking Hampers

## BAGS

**Grab & Go Vented Produce Zip Bags**



**Paper Produce Bags**



**Mesh Bags Red & Green**



## CLAMSHELLS & PULP CUPS



1/2 Pint, Pint, Quart, 1 Pound, 2 Pound, & 4 Pound Clamshells

Pint, 1/2 Pint, & Quart Pulp Cups

## BUSKETS & BASKETS



4 Quart Basket Various Colors

2, 3, 4, & 6 Quart Baskets

3 Qt. Mini-Basket Green & White

7 and 10 Oz. Burlap Sheets

## CONVENTION

# MID-ATLANTIC

## *fruit & vegetable convention*

### **Adams County Pre-Convention Bus Tour**

Monday, January 30, 2023

7:45 a.m. — 5:30 p.m.

Cost is \$70 and includes lunch. Departure and return is from the Hershey Lodge Chocolate Lobby.



**Hollabaugh Bros. Fruit Farm and Market – Biglerville, PA.** Hollabaugh Bros. has been growing and marketing fruit and vegetable crops from their 500-acre farm and other local producers for over 65 years. Their market features fresh produce, gourmet food items, baked goods, gifts, local meats, ice cream, and prepared foods, and an educational “Bee Room”. This operation hosts numerous festivals and tours throughout the year, and even offers family-focused cooking classes. [hollabaughbros.com](http://hollabaughbros.com)



**Rice Fruit Company – Gardners, PA.** Rice Fruit Company is a fruit grower/packer/shipper located in Adams County, PA. Adams County, commonly referred to as “apple country,” is known for its ideal topography for growing tree fruits. The Rice Family has been growing apples since the 1790’s and Rice Fruit Company was founded in 1913. Over the last 100+ years, Rice Fruit has expanded its operation to include fruit packing for over 40 local fruit growers. We’ll tour the packing operations which utilize some of the most up-to-date technologies available, and learn about protocols the company has in place to ensure delivery of high-quality products and food safety compliance. [ricefruit.com](http://ricefruit.com)



**Hickory Bridge Farm and Restaurant – Orrtanna, PA.** We’ll have lunch served family style in Hickory Bridge’s historic barn that is about 150 years old built of chestnut and oak. Lunch will feature Adams County apples. During lunch, we’ll be greeted by Mary Lynn, owner/operator and we’ll hear about how they manage a restaurant, bed-and-breakfast operation, special events venue, and farming. [www.hickorybridgefarm.com](http://www.hickorybridgefarm.com)



**Musselman Greenhouses – Cashtown, PA.** This operation consists of an acre and a half of greenhouses dedicated to growing seasonal blooming plants and foliage plants. Musselman’s are mostly a wholesale operation selling to garden centers, florists, hardware stores, farm markets, and other greenhouses in six states. In addition to their wholesale operation, their greenhouses are also open for retail sales year-round. [musselmangreenhouses.com](http://musselmangreenhouses.com)



**Adams County Nursery – Aspers, PA.** ACN is a family business founded in 1905, and is currently operated by the 5<sup>th</sup> generation. They supply fruit trees and orchard supplies to commercial growers in the multiple growing regions and also operate 200+ acres of apple and peach orchard. This time of the year they are busy inventorying the tree crop and we’ll spend some time in their grading and storage facilities discussing the lifecycle of a nursery crop. [acnursery.com](http://acnursery.com)

PRE-REGISTRATION IS REQUIRED. REGISTER WITH THE GROUP OF YOUR CHOICE AT :  
**WWW.MAFVC.ORG/REGISTRATION**

For more information, visit [www.mafvc.org](http://www.mafvc.org) or call 717-677-4184 or 717-694-3596

## CONVENTION

## 2023 Pre-Convention Workshops

The following pre-convention workshops and bus tour will be offered on Monday, January 30, 2023:

**01 Greenhouse Vegetables**

Sponsored by ProFarm Group and Griffin Greenhouse Supplies  
\$50 includes lunch

8:30 a.m. to 4:00 p.m.

8:30 Registration

9:00 Getting Started Considerations and Experiences – Dr. Richard Snyder, Mississippi State Univ. Retired

9:45 Variety Selection for Indoor Production - Evelyn Zaleski, Seedway Seeds

10:30 Water Quality and Modifying Water Quality - Steven Bogash, ProFarm Group

11:00 Nutrition Basics for Leafy Greens and Fruiting Crops - Krystal Snyder, Penn State Extension

11:30 Biological Insect and Mite Management - Steven Bogash, ProFarm Group

12:00 Lunch Break - Included

12:45 Disease Management - Margaret McGrath, Cornell

1:30 Fogging and Spray Applications for Indoor Vegetable Growers - Brett Kroszner, Dramm Corp.

2:15 Indoor Strawberry Pest and Disease Management - Erica Hernandez, Griffin Greenhouse Supplies

2:45 Moving from Ornamentals to Vegetables - Erica Hernandez, Griffin Greenhouse Supplies

3:15 General Considerations for Lighting in Greenhouse Vegetables - Eric J. Stallknecht, Michigan State Univ.

4:00 Adjourn

**02 Food Safety Modernization Act Grower Training**

\$45 includes lunch

9:00 a.m. to 5:15 p.m.

This training is for fruit and vegetable growers and others interested in learning about: produce safety, the Food Safety Modernization Act (FSMA) Produce Safety Rule, Good Agricultural Practices (GAPs), and co-management of natural resources and food safety. This PSA course is one way to satisfy the grower training requirement of the FSMA Produce Safety Rule

as outlined in Section 112.22(c). Participants in the course will learn about:

- Microorganisms relevant to produce safety and where they may be found on the farm;
- How to identify microbial risks, practices that reduce risks, and how to implement produce safety practices on the farm;
- Requirements in the FSMA Produce Safety Rule and how to meet them.

After attending the entire course, participants will be eligible to receive a certificate from the Association of Food and Drug Officials (AFDO) that verifies they have completed the training course. The Pennsylvania Food Safety Resource Center is providing funds to cover AFDO certification fees and course material costs for this workshop.

**04 Spotted Lanternfly Permit Training**

\$25 (no lunch)

1:00 to 3:00 pm

If your Pennsylvania business requires the movement of products or vehicles, you are required to obtain the SLF permit. A permit shows other businesses and states your due diligence to avoid transporting SLF to new areas. This 2-hour session will include the required education and exam to get the SLF permit.

**050 Starting & Improving your Farm Transition Plan**

\$25 (no lunch)

9:00 a.m. to 12:00 p.m.

Join Penn State Extension Educators from the Farm Transition Team for this half-day workshop. We will be focusing on topic areas to start, improve, and/or refresh your overall farm transition planning goals. Farm/ag business owners and operators of all levels are welcome.

- 9:00 How to Find a Successor - Lynn Kime & Christi Powell, Penn State Extension
- 10:00 How to Transfer Your Assets & Tax Implications - Sam Gehrett & Paula Ledney, Penn State Extension
- 11:00 Case Study & Wrap-Up - Entire Farm Transition Team
- 12:00 Adjourn

Continued on page 13

## Two Locations to Serve You Better!



### Nolt's Greenhouse Supplies

Specializing in Greenhouse and Nursery Growing Supplies

**(717) 354-8376**

151 E. Farmersville Road  
Ephrata, PA 17522



### Nolt's Produce Supplies, LLC

Specializing in Vegetable Growing Supplies and Equipment

**(717) 656-9764**

152 N. Hershey Avenue  
Leola, PA 17540



Compact Raised Bed Mulch Layer



Greenhouses & High Tunnels



Hyd Reset Mulch Lifter



Hyd Drive Wrapper



Water Wheel Transplanter

Please contact us for our free commercial growers catalogs or view it on our website: [www.noltsproducesupplies.net](http://www.noltsproducesupplies.net)

## NEWS

**060 Pennsylvania Pesticide Applicators License Training****\$75 includes lunch and manual****9:00 a.m. to 4:00 p.m.**

If you intend to purchase and/or apply restricted use pesticides for the purpose of producing an agricultural commodity on land which is owned or rented by you, then you need a Pennsylvania Department of Agriculture Pesticide License. To become a certified private applicator, testing is required. This full day session on January 30 will cover the basics and prepare you for the pesticide applicator's exam which will take place the next morning, January 31, from 8:30 a.m. – 11:30 a.m.

**070 Managing A Profitable Farm Market Bakery****\$20 (no lunch)****1:00 to 4:30 p.m.**

Having a bakery within your farm market is a big commitment. Once you decide to do it, there is no going back. It's adding another business within your business. Whether you have a bake-off bakery or a scratch bakery, it needs to be managed well and it needs to be profitable. In this workshop we'll hear from three markets who's bakeries are a destination experience! Topics include: best practices, baked goods as a community fundraiser, workforce management and other innovative ideas. Speakers are: Tad Kuntz,] with the Masonic Village Farm Market; Josh Smith & Holly Haas with Frecon Farm and Calib Torrice with Tabora Farm

**080 Young Grower Alliance Workshop - Tree Fruit Pruning****Fruit Research and Extension Center, 290 University Dr, Biglerville, PA 17307****\$30 (no lunch)****2:00 to 4:00 p.m.**

Please join the Young Grower Alliance (YGA) for a pruning demonstration/pre-conference workshop at the Fruit Research and Extension Center in Biglerville (not at the Hershey Lodge!). Dr. James Schupp will be providing hands-on pruning information. Dr. Schupp has done many research projects on pruning fruit trees and his expertise is recognized nationally. This workshop will take place outside, so please wear appropriate attire. Meals will NOT be provided during the workshop.

**090 Adams County Bus Tour****\$70 (includes lunch)****7:45 a.m. to 5:30 p.m.**

*Departure and return is from the Hershey Lodge Chocolate Lobby. See details on page 10.*

**Convention Proceedings**

If you cannot attend the Convention, you can purchase a copy of the Proceedings which contains summaries of many of the vegetable, small fruit, greenhouse and marketing presentations. Use the form on page 34.

# PROHARVEST AD

CONVENTION

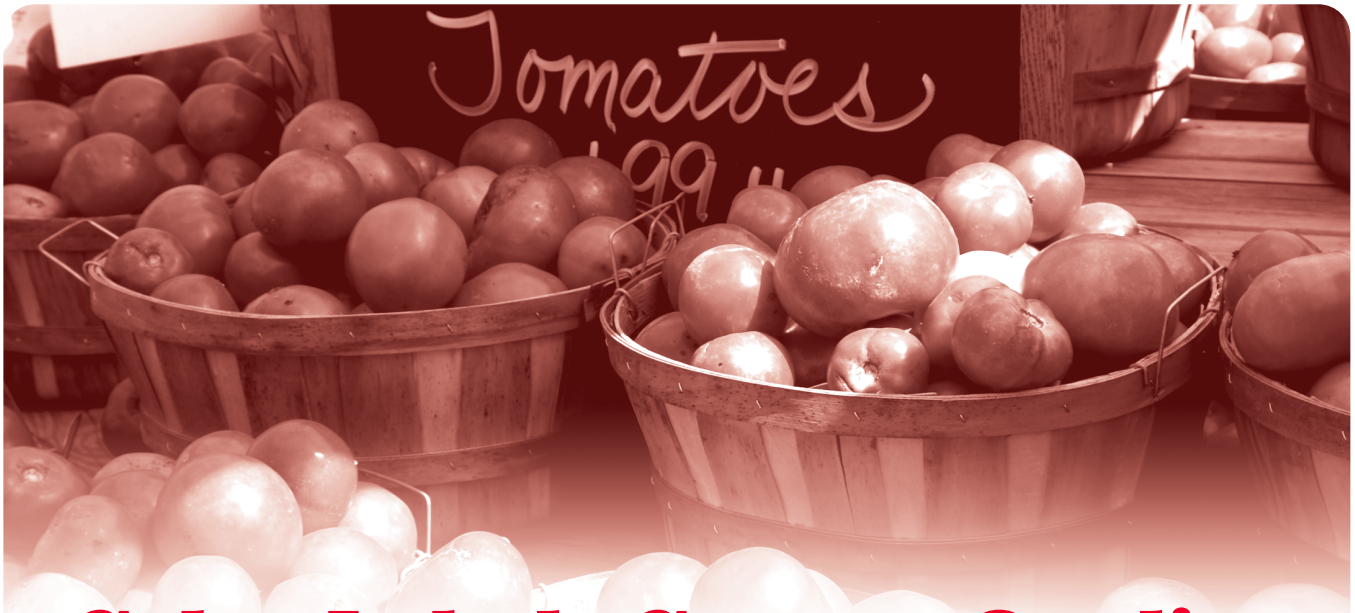

# Color Labels Convey Quality

*Show off your brand and demonstrate the superiority of your products*

Color labels enhance your brand and instill confidence in your customers. For over three decades Texpak has been making both fully pre-printed and partially pre-printed labels for our customers, helping them add branding to their products and differentiate themselves from the competition.

Our most common label solution is the partially pre-printed label. For this type of label, we will pre-print your logo and any other branding information on part of the label, leaving a section blank for you to run through our printer. This allows you to have only one label that can be used on all your products.

In addition to labels, Texpak offers a large variety of pot stakes and other horticulture labeling supplies, all of which can be run through an inexpensive thermal transfer printer. These supplies can be used for everything from FSMA labels to product/species identification.

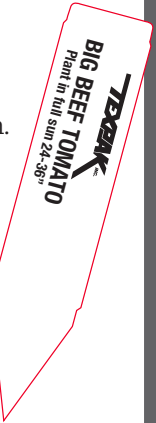

**We're here to help you find the right labeling solution for you. Contact us today to speak with one of our expert sales executives.**



*Simple Solutions to Complicated Problems Since 1934*

130 New Hyde Park Road  
Franklin Square, New York 11010  
info@texpak.com

**800-645-3416**

[www.texpak.com](http://www.texpak.com)

## CONVENTION

## 2023 Mid-Atlantic Fruit and Vegetable Convention Program

The following is the detailed educational program for the 2023 Mid-Atlantic Fruit and Vegetable Convention from January 31 to February 2.

\* denotes topics that are expected to qualify for category pesticide applicator update training credits

\*\* denotes topics that are expected to qualify for core pesticide applicator update training credits

\*\*\* denotes topics that are expected to qualify for fumigation pesticide applicator update training credits

### Tuesday Morning, January 31, 2023

#### 11 High Tunnels - Magnolia Room ABC

- 9:00 \***Cultural Controls for *Phytophthora capsici* with an Emphasis on Water Management** - Dr. Gordon Johnson, Univ. of Delaware
- 9:45 \***Phytophthora Diseases: Biology and Management** - Dr. Beth Gugino, Penn State

#### 13 Cole Crops - Crystal Room

- 9:00 **Seasonal Variety Planning for Cole Crops** - Jay Ruwet, Gowan Seed Company
- 9:45 \***Cole Crop Caterpillars and Other Insects** - Dr. David Owens, Univ. of Delaware

#### 14 Garlic - Empire Room AB

- 9:00 \***Bloat Nematode and Garlic Disease Management** - Dr. Frank Hay, Cornell Univ. (virtual)
- 9:45 **Best Practices for Great Garlic** - Dr. Gordon Johnson, Univ. of Delaware

#### 15 Urban Ag - Empire Room CD

- 9:00 **Intro/Ice Breaker/Networking** - Dan Dalton, PASA; Megan Chawner, Penn State Extension; Dr. Elsa Sanchez, Penn State

#### 16 Snap Beans - Wild Rose Room

- 9:00 **Snap Bean Heat Stress, Heat Tolerant and Yield Trials** - Dr. Emmalea Ernest, Univ. of Delaware
- 9:45 \***IPM Topics: Snap Bean Weed Management Update and Snap Bean Fungicide Research** - Dr. Lynn Sos-

noskie and Dr. Sarah Jane Pethybridge, Cornell Univ.

#### 17 Farm Market Staff Training - Cocoa Terrace/Cocoa 1

- 9:00 **Tips for Training Your Team** - Michael Kilpatrick, Growing Farmers
- 9:45 **Farm Market & Agritourism Staff Training** - Karen Paulus, Mt. Airy Orchard and Julie Keene, Flinchbaugh's Orchard and Farm Market

#### 18 Tree Fruit - Nigerian Room

- 9:00 **Invocation** - Edgar Weaver
- 9:05 **President's Address** - Andrew Schwalm
- 9:15 **George Goodling Memorial Lecture: Use of Accede and Metamitron in Apples** - Dr. Duane Greene, Univ. of Massachusetts
- 10:00 \***Safe Use of Pesticides During Tree Fruit Bloom** - Dr. David Biddinger, Penn State

#### 19 Keynote - Nigerian/Trinidad Room

- 10:45 **2022 Census of Agriculture: Your Voice, Your Future, Your Opportunity** - King Whetstone, NASS-USDA
- 11:00 **Thriving in Uncertain Times** - Michael Kilpatrick, Growing Farmers sponsored by the American Vegetable Grower magazine and American Fruit Grower Magazine

### Tuesday Afternoon, January 31, 2023

#### 21 High Tunnels - Trinidad Room

- 1:30 **Tips and Tricks of Diversified High Tunnel Production** - David King, Harvest Valley Farms
- 2:00 \***What are the Common Insect Pests Under High Tunnels and How do We Manage Them?** - Dr. Samantha Willden, Purdue Univ.
- 2:30 \*\***Understanding FRAC Codes and Resistance Management** - Leah Fronk, Penn State Extension
- 3:15 \***Detecting and Combating Hidden Diseases in High Tunnel Tomato Production** - Dr. Anna Testen, US-DA-ARS
- 4:00 **Soil Fertility Management Post Anaerobic Soil Disinfestation in a Tomato High Tunnel Production System** - Dr. Francesco Di Gioia, Penn State

## Hillside Cultivator Co. LLC



**Hydraulic adjusted cultivator**  
for the edges of plastic mulch



**Cultivators especially for**  
**Strawberries**



**Eco Weeder** for close cultivation  
around individual plants

For more information visit [hillsidecultivator.com](http://hillsidecultivator.com)

Contact: John Shenk 717-669-3158 Lititz, PA [hillsidecultivator@gmail.com](mailto:hillsidecultivator@gmail.com)

## CONVENTION

### 22 General Vegetables - Magnolia Room ABC

- 1:30 **Risky or Not? Using Agricultural Water Assessments to Manage Food Safety Risk** - Gretchen Wall, International Fresh Produce Assoc.
- 2:00 **Dealing with FSMA inspections - Grower Panel**
- 2:30 **Feasibility of Mesotunnels for Cucurbit Production** - Dr. Sarah Pethybridge, Cornell Univ.
- 3:15 **\*The Latest in Insecticide Efficacy Research** - Dr. Thomas Kuhar, Virginia Tech
- 4:00 **\*\*Lessons Learned over a Career about Vegetable Diseases, Management and Fungicide Resistance** - Dr. Margaret McGrath, Cornell Univ.

### 23 Soil Health/Cover Crops - Crystal Room

- 1:30 **Sustainable Soil Health and Fertility Management** - Dr. Zachary Hayden, Michigan State Univ.
- 2:00 **\*Potential Beneficial Aspects of Mustard Cover Crop Biofumigation** - Dr. James Jasinski, Ohio State Univ. Extension
- 2:30 **\*Using Cover Crops in Row Middles for Weed Management and Soil Health** - Dr. Alan Leslie, Univ. of Maryland Extension
- 3:15 **Reducing Tillage on Vegetable Farms** - Dr. Anu Rangarajan, Cornell Cooperative Extension
- 4:00 **\*Impacts of Weed Management on Soil Health** - Bryan Brown, Cornell Cooperative Extension

### 24 Biocontrols - Empire Room AB

- 1:30 **\*What Was Learned from 20 Years of Evaluating Bio-fungicides?** - Dr. Margaret McGrath, Cornell Univ.
- 2:00 **Biocontrol by Predators: What's Fear Got to Do With it?** - Dr. Sara Hermann, Penn State

- 2:30 **\*Contrasting Insect Biocontrols in Tunnels vs Greenhouse Production** - Dr. Laura Ingwell, Purdu Univ.
- 3:15 **\*Biocontrols for Insects and Mites** - Steven Bogash, ProFarm Group, Matthew Krause, Lallemand Inc, and Julie Graesch, BioWorks Inc.
- 4:00 **\*Biocontrols for Plant Pathogens** - Greg Rogers, Certis and Bond McInnes, AgBiome

### 25 Urban Ag - Empire Room CD

- 1:30 **\*Insect Pests and Natural Enemies on Urban Farms: What We Can Learn from a Survey in Indiana** - Dr. Laura Ingwell, Purdue Univ.
- 2:00 **Site Reclamation and Post-use Challenges for Urban Farming** - Dr. Patrick Drohan, Penn State
- 2:30 **Lessons Learned: Larger-Scale Urban Soils Remediation** - John Bixler, Hilltop Urban Farm
- 3:15 **Keynote: Focusing Energies - Finding Your Balance and Strengths** - Kafi Dixon, Common Good Farm
- 4:00 **Visualizing the Future Using Benchmarking Insights** - Dan Dalton, Pasa Sustainable Agriculture

### 26 Wholesale Marketing - Wild Rose Room

Program To Be Announced

### 27 Marketing - Cocoa Terrace/Cocoa 1

- 1:30 **How To Be A Successful Vendor at a Farmers Market** - Brian Moyer, Penn State Extension & PA Farm Markets
- 2:00 **To Be Announced** - Art King, Harvest Valley Farms
- 2:30 **To Be Announced** - Richard VanVranken, Rutgers Univ.
- 3:15 **Panel - To Be Announced**
- 4:00 **Farmers Market Data Results** - Brian Moyer, Penn State Extension & PA Farm Markets

Continued on page 16

# STOKES<sup>®</sup>

SEEDS

## Seed and Service

Stokes Seeds offers a comprehensive product line from world-class suppliers for commercial growers of all sizes. We provide grower-specific seed prescriptions to meet growers' production and profit goals.

**Stokes Seeds'**  
**Pennsylvania**  
**Seed Consultants**



**Tom Pagels**  
(609) 247-7140  
tpagels@stokeseeds.com



**Tom Dauria**  
(908) 489-4896  
tdauria@stokeseeds.com

— Quality Seed Since 1881 —

800-962-4999 | [www.stokeseeds.com](http://www.stokeseeds.com) | 13031 Reflections Dr Holland MI 49424

## CONVENTION

### Mid-Atlantic Convention Program

*continued from page 15*

#### 28 Tree Fruit - Nigerian Room sponsored by the American Fruit Grower magazine

1:30 **\*\*What's Behind the Numbers** - Decoding Modes of Action - Kara Pittman, Penn State

#### Honeycrisp Mini Seminar

2:00 **Impact of Rootstock on Bitter Pit Occurrence in Honeycrisp** - Dr. Sherif Sherif, Virginia Tech

2:30 **Methods (Factors) to Predict Bitter Pit in Honeycrisp** - Dr. Richard Marini, Penn State

3:15 **\*Honeycrisp is a Disease Magnet: Optimizing Bitter Rot & Apple Blotch Management** - Dr. Kari Peter, Penn State

3:45 **Our Experiences with Honeycrisp: A Grower Panel** - Moderator: Dr. Robert Crassweller. Growers: Tom Garretson, PA, Phil Green, NJ, Guy Moore, MD, and Henry Chiles, VA

#### Tuesday Evening, January 31, 2023

#### Annual Fruit & Vegetable Growers Banquet (ticket required)

6:00 **Reception** - Chocolate Lobby

7:00 **Buffet Dinner, Awards** - Nigerian/Trinidad Room

#### Wednesday Morning, February 1, 2023

#### 31 Tomatoes - Magnolia Room ABC sponsored by the American Vegetable Grower magazine

9:00 **How Tomato Nutrition Relates to IPM** - Elizabeth Buck, Cornell Univ.

9:30 **Becoming at Plant Detective; Learn to Think 360 Degrees** - Steven Bogash, ProFarm Group

10:15 **Tomatoes: A Recap of 2022 and an Interactive Discussion on Fertility** - Thomas Butzler, Megan Chawner, Dr. Timothy Elkner, and Robert Pollock, Penn State Extension

11:00 **\*Understanding Soilborne Diseases and Their Management** - Dr. Beth Gugino, Penn State

11:30 **PVGA Annual Meeting** - Crystal Room - All members are urged to attend.

#### 32 Basic Vegetable Production - Crystal Room

9:00 **Irrigation Basics 101** - Trevor Hardy, Brookdale Fruit Farm

9:30 **Water Quality Matters** - Thomas Ford, Penn State Extension

10:15 **\*Insect Management in Vegetables** - David Owens, Univ. of Delaware

11:00 **\*Developing Your Weed Control Program** - Dr. Timothy Elkner, Penn State Extension

11:30 **PVGA Annual Meeting** - Crystal Room - All members are urged to attend.

#### 33 Organic Vegetable Production - Empire Room AB

9:00 **To Be Announced** - To Be Announced

9:30 **Organic Beekeeping Basic** - Dr. Robyn Underwood, Penn State Extension

10:15 **Learnings from the Rodale Vegetable Systems Trial** - Dr. Gladis Zinati, Rodale Institute

11:00 **To Be Announced** - To Be Announced

11:30 **PVGA Annual Meeting** - Crystal Room - All members are urged to attend.

*Continued on page 18*

### Produce Growing Supplies

#### Early Order Discounts

Starting Dec. 12<sup>th</sup> 2022

Through Jan. 13<sup>th</sup> 2023

Irrigation Fittings

Irritec Drip Tape

Blue Layflat Hose

Plastic Mulch

Bio-degradable Mulch

Tomato Stakes

Tomato Twine

Floating Row Cover

Trellis Net

Ground Cover



We cut custom length greenhouse and high tunnel plastic. Order the length you need.

- \* clear
- \* anti-drip
- \* black/white
- \* IR
- \* anti-dust
- \* diffused



**sungro**  
HORTICULTURE  
Our Expertise is Growing®

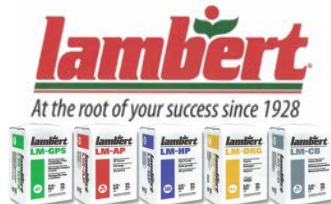

Gristmill Farm  
201 Gristmill Road  
New Holland PA 17557  
717-354-8443

CONVENTION



RUPP FEATURE:

Carbonado Gold is a 100-day, very uniform 40 count pumpkin. Dark orange with black handles makes this an industry standard.



OCTANE

Octane is extremely tender and sweet. Matures in 78 days, but this variety will hold onto the stalk for an extended time.



RACEWAY

Raceway works good for late season planting. A 54-day slicer with a strong multi-virus resistance package and uniform appearance.



RUPP'S TURK'S TURBAN

Rupp's Turk's Turban is one large turban. This 110-day turban weighs between 15-25 pounds. Orange with green and white.

Visit our booth at the 2023 Mid-Atlantic Fruit and Vegetable Convention!

More than 1,000 seed varieties at [ruppseeds.com](http://ruppseeds.com)

Questions/Orders: 1-800-700-1199



RAISING THE BAR  
IN QUALITY, FLAVOR, & YIELD

## CONVENTION

### Mid-Atlantic Convention Program *continued from page 17*

#### 34 Greenhouse Ornamentals - Empire Room CD

- 9:00 **Building a Fertility Program From Start to Finish** - Erica Hernandez, Griffin Greenhouse Supplies
- 9:30 **\*Managing Water Quality** - Krystal Snyder, Penn State Extension
- 10:15 **Best of the Penn State Flower Trials** - Sinclair Adam, Penn State Extension
- 11:00 **Media Matters; Managing Watering** - Troy Buechel, Premier Tech and Brett Kenney, Berger
- 11:30 **PVGA Annual Meeting** - Crystal Room - All members are urged to attend (or fifth Topic)

#### 35 Marketing - Trinidad Room

- 9:00 **Creating an On-Farm Retail Market** - Brian Moyer, Penn State Extension, Art King, Harvest Valley Farms and Tad Kuntz, Masonic Village
- 10:15 **Consumer Trends** - Claudia Schmidt and Kathleen Kelley, Penn State
- 11:00 **Collecting Customer Insights** - Miranda Harple, Penn State Extension
- 11:30 **Get Better Business Photos with your Phone** - Miranda Harple, Penn State Extension

#### 36 Small Fruit - Cocoa Terrace/Cocoa 1

- 9:00 **How Low Tunnels Improve Effectiveness of Strawberry Biocontrols** - Dr. Samantha Willden, Purdue Univ.
- 9:30 **What We've Learned about Growing Berries over the Years** - Michael Groszkiewicz, Mason Farms
- 10:15 **Basics of Strawberry Production Using Plasticulture** - Timothy Nourse, Nourse Farms
- 11:00 **Roles Cover Crops Can Play When Growing Berries and Other Crops** - Heidi Reed, Penn State Extension
- 11:30 **\*\*Practical Adjuvant Use: Helping Growers Understand When, Where, and Why** - Collin O'Neill, Helena Agri-Enterprises

#### 37 Labor/Farm Management - Magnolia Room D Program To Be Announced

#### 38 Tree Fruit - Nigerian Room *sponsored by the American Fruit Grower magazine*

- 9:00 **\*Codling Moth and Oriental Fruit Moth Management in Orchards** - Dr. Greg Krawczyk, Penn State
- 9:30 **Update on Precision Agriculture Technologies for**

- Tree Fruit Orchards** - Dr. Long He, Penn State
- 10:15 **Split Happens: An Overview of Apple Fruit Cracking & Splitting** - Dr. Tom Kon, North Carolina State Univ.
- 10:45 **Update from U.S. Apple Association**
- 11:15 **\*Do a Better Job on Thinning Apples Based on 50 Years Experiences** - Dr. Duane Greene, Univ. of Massachusetts

#### 39 Spanish - Wild Rose Room

- 9:00 **Welcome and Ice Breaker** - Penn State Latinx Agricultural Network
- 9:30 **Hand-on Grafting** - Donald Seifrit and Maria Gorgo, Penn State Extension
- 10:30 **Blueberry Production and Pruning** - Raphi Rezza, Virginia State Univ.
- 11:15 **Worker Protection Standard Training** - Maria Gorgo, Penn State Extension and Beth Sastre, Virginia Cooperative Extension

### Wednesday Afternoon, February 1, 2023

#### 41 Basic Vegetable Production - Magnolia Room ABC

- 1:30 **Basic Seasonal Nutrition for Solanaceous Crop** - Steven Bogash, ProFarm Group
- 2:00 **Vine Crop Nutrition** - One Plan Does Not Fit All! - Dr. Timothy Elkner, Penn State Extension
- 2:30 **Mulching to Maximize Production** - Dr. Annette Wszelaki, Univ. of Tennessee
- 3:15 **\*Considerations When Developing a Disease Management Program** - Dr. Beth Gugino, Penn State
- 4:00 **Starting Right with High Tunnel Production** - Dr. Matt Kleinhenz, Ohio State Univ.

#### 42 Organic Vegetable Production - Crystal Room

- 1:30 **Reduced Tillage in Organic Systems** - Dr. Anu Rangarajan, Cornell Univ.
- 2:00 **Tarping For Managing Weeds** - Jason Lilley, Univ. of Maine
- 2:30 **Managing Nutrients Discussion** - Megan Chawner and Elsa Sanchez, Penn State
- 3:15 **Mending the Stress Fence** - Cynthia Pollich, Penn State Extension
- 4:00 **Interseeding Cover Crops in Late Season Vegetables** - Jason Lilley, Univ. of Maine



See us for your  
weed control needs

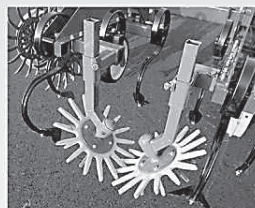

Finger Weeder



Rotary Hoe with Shield

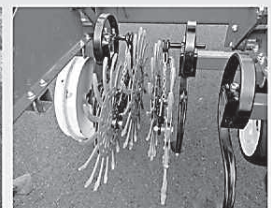

Rotary Hoe with  
Walking Beam

We also carry:

- Cover Crop Rollers
- Non-plugging
- Sickle Bar Mowers

**I & J**  
mfg. LLC

**(717) 442-9451**

10 South New Holland Road, Suite 2  
Gordonville, PA 17529

## CONVENTION

### 43 Stone Fruit - Empire Room AB

- 1:30 **Respirator Fit Testing: It's Not As Scary As You Think** - Joni Davis, Penn State
- 2:00 **Ernie Christ Lecture: \*Optimizing Chemical Fruit Thinning Strategies for Peaches** - Dr. Dario Chavez, Univ. of Georgia
- 2:45 **\*Biorational Control of Peach Blossom Blight** - Dr. Norm Lalancette, Rutgers Univ.
- 3:30 **Freeze Protection of Peaches Using Nanocellulose** - Dr. Dario Chavez, Univ. of Georgia

### 44 Greenhouse Ornamentals - Empire Room CD

- 1:30 **\*Management of Damping-off and Root Rot** - Margery Daughtrey, Cornell Univ. (Virtual)
- 2:00 **\*Managing Tough Insects and Mites with Biopesticides** - Steven Bogash, ProFarm Group
- 2:30 **\*\*Fogging Applications** - Brett Kroszner, Dramm Corp.
- 3:15 **Scouting and Training Your Team to Prevent and Solve Problems** - Erica Hernandez, Griffin Greenhouse Supplies
- 4:00 **Really Tough Perennials** - Sinclair Adam, Penn State Extension

### 45 Diversification in Agritourism - Trinidad Room

- 1:30 **Let's Try Something Else! Resources for Agritourism Diversification** - Dr. Claudia Schmidt and Christi Powell, Penn State Extension
- 2:00 **Making Your Farm Insta-Perfect** - Claudia Gil Arroyo, Rutgers Cooperative Extension
- 2:30 **Agritourism Activities from a Local Municipal Perspective** - Peter Wulfhorst, Penn State Extension

- 3:15 **How to Pick Which Activities are Right for You and Your Customers?** - Producer panel: Lisa Godfrey, Godfrey's Farm, Megan & Jason Coopey, Way Fruit Farm, and Brandon Bear, Meadowbrooke Gourds
- 4:00 **How to Pick Which Activities are Right for You and Your Customers?** - Producer Panel continued

### 46 Small Fruit - Cocoa Terrace/Cocoa 1

- 1:30 **\*Where Strawberry Anthracnose Hides** - Leah Fronk, Penn State Extension
- 2:00 **Overview of a Project to Develop New Propagation Strategies for the Strawberry Industry** - Peter Nitzsche, Rutgers Cooperative Extension
- 2:30 **Performance of Blackberry Varieties** - Dr. Alan Leslie, Univ. of Maryland
- 3:15 **\*Herbicides for Berries and Their Strategic Uses** - Ronald David Myers, Univ. of Maryland
- 4:00 **\*Bramble Viruses: Results of a PA survey and Their Management** - Kathleen Demchak, Penn State

### 47 Labor/Farm Management - Magnolia Room D Program To Be Announced

### 48 Tree Fruit - Nigerian Room

- 1:30 **\*Controlling Problem Weeds in Orchards** - Dr. Caio Brunharo, Penn State
- 2:00 **\*Managing Pear Shoot Blight & Fire Blight with Regalia** - Matheus C. Borba, Virginia Tech
- 2:45 **High Density Pear Plantings Grower Panel** - Moderator: Donald Seifrit, Growers: Clair Kauffman, PA, Steven Frecon, PA, Lynn Moore, MD, and Jason Mattson, VA
- 3:30 **Litigation Issues Surrounding Pesticide Use** - Brook Duer, Penn State

Continued on page 20

## MECHANICAL TRANSPLANTER COMPANY

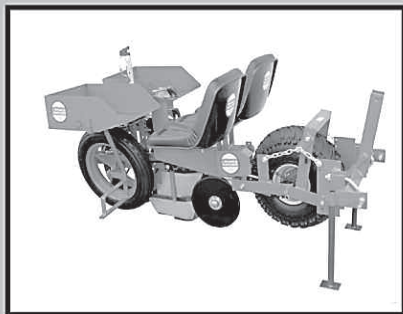

### Model 1000

- \* Excellent for bare root and small cells. Our most popular transplanter.

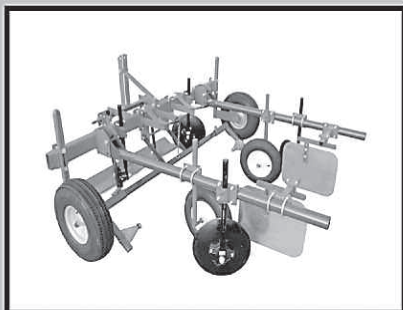

### Model 90

- \* Lays any size mulch from 3-6 feet wide.

### NEW CLEAN SEEDER



### MODEL JP-1

- \* Excellent for small seed
- \* Lightweight & easy to handle
- \* Accurate spacing

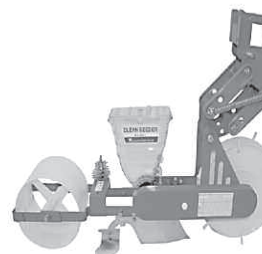

### MODEL JPH

- \* Row spacing as close as 7"
- \* Mounts on 2" square toolbar

Mechanical Transplanter Company, LLC \* 1150 Central Avenue \* Holland, MI 49423  
 Phone: 616-396-8738 or 800-757-5268 \* Fax: 616-396-3619  
 website: [www.mechanicaltransplanter.com](http://www.mechanicaltransplanter.com) \* e-mail: [mtc@mechanicaltransplanter.com](mailto:mtc@mechanicaltransplanter.com)

## CONVENTION

## Mid-Atlantic Convention Program

continued from page 19

## Wednesday Afternoon, February 1, 2023

## Social

- 5:00 **Apple Growers Reception** - Cocoa Suites 2,3,4&5  
 7:00 **Ice Cream Social** - Great Lobby (ice served from 7:00 to 8:00)

## 71 Commercializing Your Ideas - Empire Room AB

- 7:00 **Roundtable Discussion**

## Thursday Morning, February 2, 2023

## 51 Pumpkins - Trinidad Room sponsored by the American Vegetable Grower magazine

- 9:00 **\*Enemies and Friends: Pest Control and Pollinator Conservation in Pumpkins** - Dr. Kacie Athey, Univ. of Illinois  
 9:30 **Review of Powdery Mildew Management** - Dr. Margaret McGrath, Cornell Univ.  
 10:15 **Pumpkins and More at Happy Day Farm** - Timothy Stockel, Happy Day Farm, New Jersey  
 11:00 **Pumpkins and No-till, It Can Work!** - Brian Campbell, Brian Campbell Farms  
 11:30 **Breaking Down Biodegradable Mulches for Your Production System** - Dr. Annette Wszelaki, Univ. of Tennessee

## 52 General Vegetables - Magnolia ABC

- 9:00 **\*Evaluation of Grafted Watermelon for Fusarium Wilt Management** - Benjamin Beale, Univ. of Maryland Extension  
 9:30 **\*Vegetable Integrated Weed Management with Plasticulture and Cover Crops** - Dwayne Joseph, Univ. of Maryland Extension  
 10:15 **Yield and Quality of Sweetpotato Grown Under Protected Culture Systems** - Dr. Luis Duque, Penn State  
 11:00 **Biological Control in High Tunnel Vegetable Production** - Dr. Kacie Athey, Univ. of Illinois  
 11:30 **\*\*Pesticide Misapplications and Why They Fail** - Dr. Karly Regan, Penn State Extension

## 53 Potatoes - Empire Room AB

- 9:00 **National Potato Council Update** - Kam Quarles, National Potato Council  
 9:30 **PotatoesUSA Update** - Kimberlee Breshears, PotatoesUSA  
 10:15 **Growing Potatoes when it is just too darn Hot to grow Potatoes** - Robert Leiby, PA CoOp Potato Growers, Inc.  
 11:00 **Penn State Potato Research Variety Trials in 2022** - Dr. Xinshun Qu, Penn State  
 11:30 **Potato Insect Update** - Tom Kuhar, Virginia Tech

## 54 Cut Flowers - Empire Room CD

- 9:00 **Creating a Network of Cut Flower Growers in Maine** - Jason Lilley, Univ. of Maine  
 9:30 **Identifying Cut Flower Grower Needs: How Cooperative Extension in NYS is Working to Serve the Industry** - Dr. Elizabeth Lamb, Cornell Univ.  
 10:15 **\*Weed Control Options for Cut Flowers** - Alan Leslie, Univ. of Maryland  
 11:00 **Growing in High Tunnels** - Laura Beth Resnick, Butterbee Farm

## 55 Marketing and Production Tips for High Value Niche

## Crops - Cocoa Terrace/Cocoa 1

- 9:00 **Cooperative Direct Marketing to Enhance Diversity of Farm Products at Walking Bird Farm** - Jennifer LaMona, Walking Bird Farm  
 9:30 **Growing and Marketing Ginger and Turmeric in Moveable Tunnels** - Alex Sawarsky, Rutgers Gardens: Bill Errickson, Rutgers Cooperative Extension  
 10:15 **Digital Marketing Tips for Niche Crops - Small Farms/Big Sales** - Rebecca Kutzer-Rice, Moonshot Farm and Brendon Pearsall, Rutgers Cooperative Extension  
 11:00 **Ethnic Crops and Organic Wildcrafting to Enhance Customer Diversity and Marketing Potential** - Allison Akbay, Snapping Turtle Farms  
 11:30 **Roundtable Discussion with Session speakers**

## 56 Small Fruit - Crystal Room

- 9:00 **Blueberries: Marching to the Beat of a Different Drummer** - Robert Pollock, Penn State Extension  
 9:30 **Wild Bees and the Secret to Bigger Berries** - Dr. Margarita López-Urbe, Penn State  
 10:15 **Caring for Figs** - William Muzychko, Bill's Figs  
 11:00 **\*Efforts to Establish a Natural Enemy of SWD in the Mid-Atlantic and Beyond** - Dr. Cesar Rodriguez-Saona, Rutgers Univ., Dr. Kelly Hamby, Univ. of Maryland and Kathleen Demchak, Penn State

Continued on page 22

## Refrigerated and Ventilated Cooling Systems for Fruit and Vegetable Storages

- COMMERCIAL REFRIGERATION
- DESIGN, SALES AND SERVICE
- SERVING AGRICULTURE FOR OVER 70 YEARS

Free Consultation and Quote

Call Mike Mager at 585-343-2678



# ARCTIC

REFRIGERATION CO. OF BATAVIA

26 Cedar Street, Batavia, NY 14020

www.arcticrefrigeration.com

CONVENTION

# Gowan<sup>®</sup> USA

Providing specialized solutions to  
fruit and vegetable growers since 1962

**Badge<sup>®</sup> SC**  
Fungicide/Bactericide

**TORINO<sup>®</sup>**  
FUNGICIDE

**QUINTEC<sup>®</sup>**  
FUNGICIDE

**REASON<sup>®</sup>**  
500 SC FUNGICIDE

**Gavel<sup>®</sup>**  
Fungicide  
75DF

**Prefar<sup>®</sup> 4-E**  
Selective Herbicide

**SANDEA<sup>®</sup>**  
HERBICIDE

**Zing!<sup>®</sup>**  
Fungicide

**Badge<sup>®</sup> X<sub>2</sub>**  
Fungicide/Bactericide  
OMRI LISTED

**EcoSwing<sup>®</sup>**  
BOTANICAL FUNGICIDE  
OMRI LISTED

[GOWANCO.COM](http://GOWANCO.COM)

**Gowan<sup>®</sup>  
USA**

Torino<sup>®</sup> is a registered trademark of Nippon Soda Co., Ltd. Quintec<sup>®</sup> is a registered trademark of Nissan Chemical Corporation. Badge<sup>®</sup>, Prefar<sup>®</sup>, Sandea<sup>®</sup> and Reason<sup>®</sup> are registered trademarks of Gowan Company, L.L.C. Ecoswing<sup>®</sup>, Gavel<sup>®</sup>, and Zing!<sup>®</sup> are registered trademarks used under license by Gowan Company, L.L.C. The OMRI Listed seal is a registered trademark of OMRI. Always read and follow label directions.

## CONVENTION

## Mid-Atlantic Convention Program continued from page 20

### 57 Stone Fruit - Wild Rose Room sponsored by the American Fruit Grower magazine

- 9:00 **\*Use of Accede for Chemical Thinning Peaches in Mid-Atlantic** - Dr. James Schupp, Penn State
- 9:30 **Update on Peach Rootstocks and Grower Demonstration Sites** - Dr. James Schupp, Penn State
- 10:15 **National Peach Council Update** - Kay Rentzel, National Peach Council
- 10:45 **\*Optimizing Peach Management Programs with New Materials & Mating Disruption** - Dr. Anne Nielsen, Rutgers Univ.
- 11:30 **Solutions to Armillaria Root Rot Replant Disease & Its economic Impact on Stone Fruit** - Tyler Mark and Dr. Greg Reighard, Clemson Univ.

### 58 Tree Fruit - Nigerian Room

- 9:00 **\*\*WPS Compliance What You Need to Know to be in Compliance** - Joni Davis, Penn State Univ.
- 9:30 **Economics of Replanting an Orchard** - Dr. Jay Harper, Penn State
- 10:15 **Predicting Apple Fruitlet Abscission with New Technologies** - Dr. Tom Kon, North Carolina State Univ.
- 11:00 **\*\*\*Nematode Control: Biofumigation & Other Strategies** - Dr. Kari Peter, Penn State
- 11:30 **\*Identification of Colletotrichum Causing Apple Bitter Rot & Management Options** - Dr. Srdjan Acimovic, Virginia Tech

### Thursday Afternoon, February 2, 2023

#### 61 Sweet Corn - Trinidad Room

- 1:30 **\*Tar Spot Identification and Management** - Dr. Alyssa Collins, Penn State
- 2:00 **NJ Grower Panel** - Jeremy Compton, America's Grow a Row and Craig Steely, Alstede Farms
- 2:45 **\*Comparing Trap Types and Pheromone Lures for Catching Corn Earworm Moths** - Dr. Brian Nault, Cornell Univ.
- 3:15 **\*\*Record-Keeping Requirements for Private Applicators** - Ed Crow, Penn State Extension
- 3:45 **\*Weed Management in Sweet Corn** - Dwight Lingenfelter, Penn State

#### 62 Pollinators - Magnolia Room ABC

- 1:30 **What Makes a Good Pollinator and the Economic Benefits of Maximizing Crop Pollination** - Dr. Margarita López-Urbe, Penn State
- 2:00 **Pollination Contracts** - Dr. Robyn Underwood, Penn State Extension, and beekeeper panelists Mark Gingrich, Lindsey Moroch, and Grant Stiles
- 2:45 **Bumblebees in Greenhouse and Field Crop Production** - Agrin Davari, Plant Products
- 3:15 **\*Risk to Bees from Fungicides, Insecticides and Fungicide-Insecticide Tank Mixes** - Dr. Scott McArt, Cornell Univ.
- 3:45 **Integrated Pest and Pollinator Management for Vine Crops** - Dr. Ashley Leach, Ohio State Univ.
- 4:15 **Open Discussion** - Needs for pollination research and education topics

# **lambert**

## **PREMIUM PROFESSIONAL PEAT-BASED SUBSTRATES**



### **FOR ALL YOUR GERMINATION AND ALL PURPOSE NEEDS**



**JEFFREY P. BISHOP**  
 Cell: (315) 480-1900  
 Toll Free: (888) 632-8808  
 lambertpeatmoss@aol.com  
 www.lambertpeatmoss.com

Since 2001 Authority in Refrigeration for Agro-Industrial Applications in North America.



- Thru the Wall
- Portable
- Roof Mounted
- Hydrocoolers
- Custom Designs
- Blast Freezers
- Chillers
- Greenhouse Coolers



1.866.748.7786  
 info@kooljet.com

## CONVENTION

### 63 Potatoes - Empire Room AB

- 1:30 **\*Managing Blackleg and Soft Rot of Potato from Seed to Field and Storage** – Dr. Jianjun Hao, Univ. of Maine
- 2:00 **Managing Nitrogen and Other Nutrients on Pennsylvania Potatoes** - Jonathan Price, Sterman Masser, Inc.
- 2:45 **\*Help! My Potatoes are Rotting** – Dr. Jianjun Hao, Univ. of Maine
- 3:15 **\*\*To Be Announced Core Credit**
- 3:45 **Potato Marketing Update** - Nathan Tallman, PA CoOp Potato Growers, Inc.
- 4:30 **Annual Business Meeting** - PA CoOp Potato Growers, Inc

### 64 Equipment Technology - Wild Rose Room

- 1:30 **Sprayer+Mower Combo Designed for Orchard Use** - Dale Roberts
- 2:00 **To Be Announced**
- 2:45 **Farmer-Developed Specialized Equipment** - John Shenk, Shenk Berry Farm
- 3:15 **A Primer on Agrivoltaics and Remote-Control High Tunnel Sidewall Motors** - Dr. Matthew Kleinhenz, Ohio State Univ.

### 65 Digital Marketing and Online Sales - Cocoa Terrace/Cocoa 1

- 1:30 **Developing a Podcast** - Donald Seifrit, Penn State Extension
- 2:00 **TikTok** - Miranda Harple, Penn State Extension
- 2:45 **Online Sales Strategies: Our Experiences with Amazon** - Lonnie Kauffman, Kauffman Orchards
- 3:15 **Tricks of the Trade Roundtable** – Shannon Dill, Univ. of Maryland Extension

### 66 Small Fruit - Crystal Room

- 1:30 **Draper Drop, Blueberries that Won't Size, and More** - Dr. Gary Pavlis, Rutgers Univ.
- 2:00 **Managing Wildlife in Small Fruit Production** – Luke Macaulay and Chris Cochran, Univ. of Maryland
- 2:45 **\*What's New with Blueberry Diseases** – Dr. Peter Oudemans, Rutgers Univ.
- 3:15 **\*\*Site Analysis before Making a Pesticide Application** – Dr. Jamie Kopco, Penn State

### 67 Farm Management/Labor - Wild Rose Room Program To Be Announced

### 68 Tree Fruit - Nigerian Room

- 1:30 **\*Advances in Insect Monitoring Tools in Fruit** - Dr. Greg Krawczyk, Penn State
- 2:00 **Early Results of Two Leader Apple Tree Systems** – Dr. Robert Crassweller, Penn State
- 2:30 **Water Quality and Sanitizers when Grading Fruit & Utilization of Culls & Drops** - Dr. Rohan Tikekar, Univ. of Maryland

### Alternative Crops Sessions

- 3:00 **Potential for Hops in the Mid-Atlantic** - Bryan Butler, Univ. of Maryland
- 3:30 **Pawpaw Potential for the Mid-Atlantic Fruit Industry** - To Be Announced
- 3:50 **Hardy Kiwi Potential for the Mid-Atlantic Fruit Industry** - To Be Announced

Morrissey Insurance is proud to represent an industry as hardworking and dedicated as our farmers!

We are pleased that our customers choose to work with us!

Customer satisfaction is our number one goal.

Here's what one of our valued customers has to say when asked:

**"Why do you choose to work with Morrissey Insurance?"**

*"Morrissey is a family owned and operated business that understands the needs of our family farm and retail business. Their staff is very knowledgeable and helpful and can provide us with the various types of insurance our farm and retail business needs to keep us "safe" doing business in the Lehigh Valley. We have been with Morrissey for many years and are very happy with the service they provide."*

*Newhard Farms*



*BM* MORRISSEY  
INSURANCE  
"Insuring Your Future since 1971"

890 N. Reading Rd., Ephrata, PA 17522

13025 Route 6, Troy, PA 16947

[www.insuringyourfuture.com](http://www.insuringyourfuture.com)

**800-422-8335**

## CONVENTION

### 2023 Exhibitors

The following companies plan to exhibit at the 2023 Mid-Atlantic Convention:

|   |  |  |
|---|--|--|
| Adams County Nursery, Inc.                  | Helena Agri Enterprises                              | Penns Creek Welding                    |
| Advanced Ag East                            | Hillcrest Nursery Inc.                               | Pennsylvania Farm Bureau               |
| AgBiome                                     | Hillside Cultivator Co. LLC                          | Pennsylvania Service & Supply Inc.     |
| Agri-Dynamics                               | Honeycomb Basket                                     | Phil Brown Welding Corp.               |
| Agro Fresh                                  | Horizon Farm Credit                                  | Phoenix Labor Consultants              |
| Agro-K Corporation                          | Hybrid Seed Company                                  | Pittmoss, LLC                          |
| Aqua-Yield                                  | Inter-County Bakers Inc.                             | Plant Food Company Inc.                |
| Arctic Refrigeration Co.                    | InterCrate, Inc.                                     | PolyExpert Inc.                        |
| Arendtsville Garage                         | International Paper                                  | Pro Farm Group/Marrone Bio Innovations |
| Atticus LLC                                 | IPL/Macro Plastics                                   | ProducePackaging.com                   |
| Autrusa Inc.                                | IPM Laboratories Inc.                                | Provide Agro Corporation               |
| Avian Enterprises, LLC                      | ISP Technologies                                     | Quality Fresh LLC                      |
| Bakie Farm Initiative LLC                   | Iva Manufacturing                                    | Re-Divined                             |
| BASF  | J D Associates                                       | Robert Marvel Plastic Mulch            |
| Bayer CropScience - Seminis                 | Johnny's Selected Seeds                              | Rockford Package Supply                |
| BCS/Wes Stauffer Equipment LLC              | Keystone Bio Ag                                      | Rupp Seeds Inc.                        |
| BDI Machinery Sales Inc.                    | Keystone Fence Supplies Co.                          | Sakata Seed America, Inc.              |
| Binkley & Hurst LP                          | Kirby Agri Inc.                                      | San Agrow                              |
| Bio Safe Systems                            | KOBA Corp.   | Saunders Brothers Inc.                 |
| Bowsmith Inc.                               | Kreher Enterprise LLC                                | Saylor's Farm & Crate LLC              |
| Brandt                                      | KULT-Kress LLC                                       | Seedway, LLC                           |
| Business Resources, Inc.                    | LaGasse Machine & Fabrication, Inc.                  | Shawnee Canning Company Inc.           |
| Catalytic Generators                        | Lambert Peat Moss, Inc.                              | Signs of the Seasons                   |
| CBC America LLC                             | Martin's Produce Supplies                            | Slimline Manufacturing – Turbo-mist    |
| Center for Schools and Communities          | McCutcheon Apple Products, Inc.                      | Stauffer Huling Farms                  |
| Certis Biologicals                          | Mechanical Transplanter Co.                          | Stokes Blueberry Farms & Nursery, Inc. |
| Chester Irwin Foods, LLC/Pilgrim Provisions | Meister Media Worldwide                              | Stokes Seeds Inc.                      |
| Clifton Seed Company                        | Messick Farm Equipment, Inc.                         | Stoller USA                            |
| Cooper's Mill                               | Microbial Science Laboratories, LLC                  | Summit Tree Sales, Inc                 |
| Country Folks Grower                        | Miller Chemical and Fertilizer LLC                   | Superb Horticulture                    |
| Crop Care                                   | Monte Package Company                                | Syngenta                               |
| Dillman Farm                                | Morrissey Insurance                                  | Tallman Family Farms LLC               |
| Drape Net North America                     | NE Seed  | Targit Sales Associates, LLC           |
| DuBois Agrinovation                         | Nichino America, Inc.                                | Tew Mfg. Corp.                         |
| Durand-Wayland, Inc.                        | Noble Orchards Software Solutions                    | TEXPAK, Inc.                           |
| Evans Manufacturing Company, LLC            | Nolt's Produce Supplies LLC                          | Thunderbird Plastics Ltd.              |
| Farm Evolution                              | Nourse Farms, Inc.                                   | Tilmor                                 |
| Farm Market Specialties                     | Nutrien Ag Solutions                                 | Timac Agro USA                         |
| FMC   | Ocean Organics                                       | Toro Ag Irrigation                     |
| Farmer's Choice Foods Brands, Inc.          | OESCO, Inc.  | TRICKL-EEZ Irrigation Inc.             |
| Fisher Realty/Harvest Pro                   | OMEX Agrifluids Inc.                                 | UPL NA                                 |
| Fisher Sprayer Mfg.                         | Orchard-Rite/Superior Wind Machines                  | USDA NRCS                              |
| Full Circle Mushroom Compost, LLC           | ORO Agri   | USDA NASS                              |
| The Gardner Pie Company                     | Otis S. Twilley Seed                                 | Valent USA                             |
| Gowan Seed Company                          | PA Department of Agriculture                         | Van Well Nursery                       |
| Gowan USA                                   | PA Department of Agriculture – Bureau of Food Safety | Verdesian Life Sciences                |
| Green Star Cooperative                      | PA Preferred   | Victory Packaging                      |
| Griffin Greenhouse                          | PA Office of Rural Health – Penn State Univ.         | Wafler Nursery                         |
| Growers Equipment Center Inc.               | Pabody Insurance & Financial                         | Walker Bros. Inc.                      |
| Growers Mineral Corp.                       | PCA – Supply Services                                | Weller Insurance                       |
| Growmark FS LLC                             | PDM Insurance Agency, Inc.                           | Westbridge Ag Products                 |
| H. M. Clause, Inc.                          | Pan American Seed                                    | Willow Drive Nursery, Inc.             |
| Harris Seeds                                | Peach Ridge Orchard Supply, Inc.                     | Willie Equipment Sales, Inc.           |
|   |  | J. S. Woodhouse Co., Inc.              |

# CONVENTION

# BIO 360

Biodegradable | Compostable Mulch Film®



Made from Mater-Bi



BPI Certification



No negative impact on soil



Suitable for many types of crops



Several thicknesses available

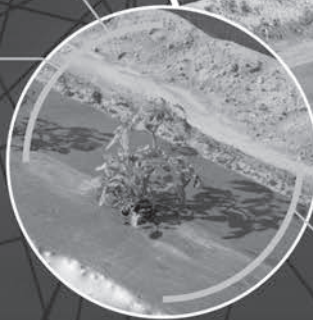

Sustainably produced



Nolt's Produce Supplies

717-656-9764 - Leola, PA

noltsproducesupplies.net

For other regions, contact us

1-844-4BIO360 (1-844-424-6360)



## FOOD SAFETY

# Tools for Writing a Farm Food Safety Plan

Luke LaBorde and Lee Stivers

Penn State Extension offers a set of templates, checklist and logs, to assist farmers of fresh fruits and vegetables in writing farm food safety plans.



For fresh fruit and vegetable growers adapting to meet the requirements of the Food Safety Modernization Act (FSMA) and third party GAP audits mandated by buyers, putting together a farm food safety plan is often a good starting point. A written farm food safety plan provides a way for growers of fresh fruits and vegetables to get organized and focused on produce safety on their farm operations. A written farm food safety plan is not specifically required by FSMA, but it is nonetheless a useful tool in complying with FSMA. A written farm food safety plan is usually required for third party GAP audits. A written farm food safety plan becomes a central place for growers to assess risks, outline practices to reduce those risks, record policies and standard operating procedures (SOPs), and keep needed records.

Every farm is unique and the risks on the farm will be specific to each operation. Developing a farm food safety plan should therefore be done by someone on the farm who knows the farm well, can assess risks, and identify practices to reduce risk that fit the farm.

Farm food safety plans can have many parts, but generally include the farm name, address, and description; the name and contact information for the farm food safety manager; a risk assessment of practices and conditions on the farm that can impact food safety; a description of practices that the farm undertakes to reduce risks; and records that document those practices. Other items that can be included are farm maps, policies and SOPs, training records, monitoring and risk assessment records, water test results, supplier and buyer information, input and equipment logs, cleaning logs, and self-audits.

Penn State Extension has developed the following set of

templates, checklists and logs, patterned after the USDA Harmonized GAP audit, to assist farmers in writing their farm food safety plans:

A template plan, following the USDA Harmonized GAP audit, can be filled in section by section to create your farm food safety plan.

A sample plan, is only an example of what a farm food safety plan might look like. It is imperative that you write your own farm food safety plan to reflect your own farm operation and conditions.



The following checklists, logs and forms are templates that may also be useful as sections in your farm food safety plan:

- Annual self-audit
- Pre-harvest risk assessment
- Animal and wildlife monitoring
- Buyer contact list
- Employee training log
- Equipment cleaning log
- Manure application records
- Packing house cleaning log
- Restroom cleaning log
- Traceability mock recall exercise
- Truck checklist
- Wash water treatment log
- Equipment list

The above templates and samples are available online at <https://extension.psu.edu/tools-for-writing-a-farm-food-safety-plan>

*Dr. LaBorde is with the Department of Food Science at Penn State and Lee Stivers is a former Penn State Extension Educator. From Penn State Extension, <https://extension.psu.edu/tools-for-writing-a-farm-food-safety-plan>, May 1, 2018*

## STAND 'N PLANT

|  |  |
|--|--|
| <h3 style="margin: 0;">SEEDER</h3> <p>Use for...</p> <ul style="list-style-type: none"> <li>• Seeds</li> <li>• Onions</li> <li>• Garlic</li> </ul>  | <h3 style="margin: 0;">PLANTER</h3> <p>Use for...</p> <ul style="list-style-type: none"> <li>• Transplants</li> <li>• Potatoes</li> <li>• Bulbs</li> </ul>  |
|--|--|

*Easily plant hundreds of seeds or plants per hour into plastic covered or bare ground seed beds.*

## Stand 'N Plant

95 Rose Road, Saltsburg, PA 15681

Phone: 724-639-3965 or visit: [www.standnplant.com](http://www.standnplant.com)

# NOURSE

Delivering Quality

High-quality plants.  
Exceptional customer service.

## It's our mission. Literally.



NourseFarms.com | 413-665-2658 | [info@noursefarms.com](mailto:info@noursefarms.com)

## FOOD SAFETY

### Penn State Offering FSMA Training Courses

The Food Safety Modernization Act (FSMA) is the most comprehensive change to produce farming in the past 70 years. Farms with less than \$28,000 in gross sales are not covered under this Act. Also growers who exclusively grow crops not normally consumed raw like potatoes, pumpkins, and sweet corn, for example are not covered by FSMA

One of the requirements of the law is that all growers covered under the Act attend a Grower Training Course. Participants will receive a notebook and receive a certificate of attendance. The cost is \$30 per grower. The course will cover seven hours of instruction time that will be spent on the following modules:

- Introduction to Produce Safety
- Worker Health, Hygiene, and Training
- Soil Amendments
- Wildlife, Domesticated Animals, and Land Use
- Agricultural Water (Part 1: Production Water and Part 2: Postharvest Water)
- Postharvest Handling and Sanitation
- How to Develop a Farm Food Safety Plan

After attending the entire course, participants will be eligible to receive a certificate from the Association of Food and Drug Officials verifying that they have completed the training.

#### Dates and Locations:

- January 10, 2023, Madisonburg, Kinfolk by Keystone Family Farms
- February 21, 2023, Mercer, Mercer County Extension Office
- February 23, 2023, New Holland, Yoder's Country Market and Restaurant
- March 1, 2023, Bloomsburg, Columbia County Extension Office
- March 6, 2023, Oxford, Oxford Produce Auction

To register for the above trainings, please visit <http://extension.psu.edu/fsma-grower-training> or call 1-877-345-0691. Checks, credit cards, and debit cards are accepted.

Penn State will also be offering this training on Monday, January 30, 2023, at the Mid-Atlantic Fruit and Vegetable Convention, at the Hershey Lodge in Hershey. The cost for this training is \$45. To register for the training at the Mid Atlantic Fruit and Vegetable Conference, please call 717-694-3596.

Please direct any questions about the program to Jeff Stoltzfus at 717-394-6851.

## MRS AIR BLAST SPRAYER



5 X 5 Spray Head  
Sprays 12-15 Ft.  
on both sides

- > 23 HP Vanguard engine
- > Electric start
- > 60 gallon tank
- > Trailer hook up
- > Electric diaphragm pump





PRODUCED BY



27 W Mohler Church Rd. Ste  
1 Ephrata, PA 17522  
717-733-3015

## STATEWIDE BAG SERVICE

TOWER CITY, PA 17980

717-647-2623 or 717-460-7962

Visit our website at  
[www.tallmanpotatoes.com](http://www.tallmanpotatoes.com)

to see our full line of products

**Introducing a New Product**

**3 lb. Brown Paper Bag**

*Environmentally friendly packaging Solution*

*100% Paper with die cut holes for ventilation.*



*Completely plant based, recyclable & compostable.*

## NEWS

## Updates to Crop Insurance Plans Offer Coverage to More Growers

The U.S. Department of Agriculture (USDA) is improving two of its most comprehensive risk management safety net programs, Whole-Farm Revenue Protection (WFRP) and Micro Farm, making them more accessible to America's agricultural producers. This includes doubling the maximum insurable revenue under WFRP, now \$17 million, more than tripling the size of farm operations eligible for Micro Farm, now \$350,000 and reducing paperwork requirements for WFRP. These improvements are in direct response to feedback from stakeholders as USDA's Risk Management Agency (RMA) recognizes the important role these insurance options play for many producers, including specialty crop, organic and direct market producers.

Listening to farmers and ranchers, learning about their needs and increasing access to resources are all priorities for us at RMA," said RMA Administrator Marcia Bunger. "Over the past year and a half, we have rolled out a number of improvements to WFRP, as well as introduced the new Micro Farm program, and through updates to Whole Farm Revenue Protection and Micro Farm, RMA can now help even more local food, direct market, specialty crop and organic producers protect their operations.

### Whole-Farm Revenue Protection

The WFRP program provides protection for all eligible commodities on a farm under one insurance policy. Now, producers can insure up to \$17 million in revenue (formerly \$8.5 million).

Other updates to WFRP include:

- Allowing a producer to report and self-certify yield at the

beginning of the year for commodities without other in-surance options in a way similar to those with individual crop policies. This will significantly reduce the amount of paperwork required to apply for WFRP.

- Eliminating expense reporting to reduce paperwork burden. In place of expense reporting, WFRP will reduce the expected revenue of commodities a producer is unable to plant to 60%, similar to prevented planting for other programs.

These updates build on others recently made to WFRP, including expanded coverage and flexibilities for organic producers.

### Micro Farm

The Micro Farm program, offered through WFRP, provides a risk management safety net for all eligible commodities on a farm under one insurance policy, but on a smaller scale. Now, producers with farm operations up to \$350,000 in approved revenue (formerly \$100,000) can get coverage. RMA introduced the new Micro Farm program in 2021 to better serve direct market and small-scale producers. While the program is well received and feedback has been largely positive, industry partners and small, diversified producers have informed RMA that the current limit is too low to meet the needs of many interested producers. In response, the FCIC approved the increase in size for eligible farm operations.

The updates to WFRP and Micro Farm take effect in crop year 2023.

### More Information

Crop insurance is sold and delivered solely through private crop insurance agents. A list of crop insurance agents is available at all USDA Service Centers and online at the RMA Agent Locator. Learn more about crop insurance and the modern farm safety net at [rma.usda.gov](http://rma.usda.gov).

## Greenhouse Supplies

- Greenhouses & Supplies
- Heaters & Fans
- Fertilizers
- Irrigation
- Sprayers
- Produce Supplies



717-532-5918

888-381-8641

[MartinsProduceSupplies.com](http://MartinsProduceSupplies.com)

## New Law Changes Method of Antlerless License Sales

The way hunters apply for Pennsylvania antlerless deer licenses is about to change for the first time in decades.

Senate Bill 431, which would allow hunters to buy antlerless licenses through the HuntFishPA automated licensing service, was signed into law by the Governor. When it takes effect with the 2023-24 license year, antlerless licenses will be available for purchase online or in person at any license issuing agent.

PFB is in favor of the legislation aimed at making it easier to purchase an antlerless license when you purchase an antlered license.

The Game Commission, many hunting organizations and everyday hunters supported the bill, championing it as the final step to fully modernizing license sales.

Until now, hunters applied for antlerless licenses via mail, sending those familiar pink envelopes to county treasurers, the only entity permitted to sell them. They had to do so according to a set schedule, with various deadlines based on state residency and rounds of sales, using a self-addressed stamped envelope and paper checks, something increasingly foreign to some hunters.

There were, in short, a lot of variables in play, and that occasionally led to problems with hunters getting licenses or not.

Given all that, the pink envelope system was seen by many as a barrier to hunting participation, especially when it comes to recruiting new hunters. Allowing for antlerless license sales through HuntFishPA will address those issues.

Prior to the start of next license year, the Game Commission will notify hunters on the process for applying for an antlerless license under the new system.

*From Farm Bureau Express, Penna. Farm Bureau*



## DIVERSIFIED VEGETABLE APPRENTICESHIP

*Pasa's Diversified Vegetable Apprenticeship pairs beginning farmers with established growers to provide a guided pathway toward managing or starting a vegetable farm.*

*Apprentice Ventura Ortiz at Apple Ridge Farm, Pennsylvania*



*Apply today at [pasafarming.org/dva](https://pasafarming.org/dva)*

Applications for host farms & apprentices are reviewed on a rolling basis, however we recommend applying by February 25, 2023.

### **Apprentices**

prepare for a career in farm management and receive 2,700+ hours of paid, on-the-job training and 200+ hours of related coursework over 18 months.

### **Host farms**

train the next generation of sustainable farmers and gain access to a pool of pre-qualified employees invested in farming as a career.

Diversified Vegetable Apprenticeship is administered in Pennsylvania and the surrounding region.

## GENERAL

## Preparing Your Pesticide Shed for Winter

Lisa McKeag

It's been a warm fall but freezing temperatures are finally in the forecast. Just like all of your storage crops that require the right conditions to make it through an unpredictable winter, pesticides also need to be kept out of the cold. Now is a good time to make sure that unused pesticides are either stored or disposed of properly.

Ideally, you will have purchased only enough pesticides to get you through a single season. These products can degrade over time, as can their containers, especially under extreme temperatures. The safest way to dispose of these chemicals is to use them up, applying them to their intended targets according to the label's instructions. If you find that you're routinely storing pesticides over multiple growing seasons, talk to your dealer about special ordering smaller sized containers, or work with other growers in your community to share a larger container—be sure all parties are certified applicators if using restricted-use products. However, if you do need to store pesticides through the winter, proper storage will help them to be usable into the following season.

**The first step is taking an inventory of your pesticide shed.** This will help you with making purchasing decisions for next season, and would be very useful in the event that there is a spill, fire, or other emergency.

- **Record what you have and in what quantities**, as well as purchase or delivery dates to be sure you know how old your materials are. The average shelf life of many of these products is two years. Write purchase dates on containers with waterproof ink.
- **Read the label for special storage instructions.** Also be sure that the label and all of the use instructions are in good condition and are legible. Labels may be updated over time to reflect current research, such as the product's environmental or pollinator precautions. New, current labels can be obtained from your pesticide dealer, or can be found on-line at manufacturer's websites or the Crop Data Management Systems searchable database at <https://www.cdms.net/Label-Database/Advanced-Search>.
- **Make sure that all the products you have on your farm are registered by the EPA**, and in your state. State registrations are typically renewed on an annual basis. Remember, it is illegal to use or store any pesticide that is not currently registered in the state. Besides, if there is a chance that a pesticide that you already have is not registered, there's also a good chance that it's no longer effective, and may even be hazardous. Verify again before using any stored product that its registration status has not changed. Materials that are not registered are immediately reclassified as waste, and paying to get rid of waste can be more expensive than purchasing the product in the first place!

You can check the registration status of a product or active ingredient with these searchable databases.

National Pesticide Information Retrieval System (NPIRS) <http://npirspublic.ceris.purdue.edu/state/default.aspx>.

Pesticide Product Registration Information for Pennsylvania: <https://www.paplants.pa.gov/ProductRegFSA/BrandSearch.aspx>.

**Avoid temperature extremes and excess humidity.** Pesticides should be stored between 40° and 80°F in a lockable room or cabinet that is clearly marked for pesticide storage, on plastic or metal shelves; wood is not ideal as it will absorb spills.

- Liquid formulations should be stored inside of metal or plastic bins in case their original containers break or corrode. Liquids should never be stored above powders as they may

leak and cross-contaminate these products. Allowing liquid pesticides to freeze can result in separation or inactivation of the ingredients. This guide to Cold Weather Storage and Handling of Liquid Pesticides at <https://apps.msueextension.org/montguide/guide.html?sku=MT201801AG> from Montana State University provides a chart of many common pesticides and their tolerances for freezing/thawing, as well as how to handle frozen products to maximize their efficacy.

- **Powders, dusts, and granules** must be kept dry. Excess humidity will cause wettable powders to harden and prevent them from properly going into suspension. If a dry product may be damaged by moisture, a quick way to check if it will go into suspension is by adding a small sample to water in a mason jar at the same rate that you would apply it in the field, capping it tightly, and shaking it. You will be able to see if it is able to dissolve. If it won't dissolve in the jar, it won't dissolve in a tank mix either, and you would end up spraying weak or inconsistent concentrations on your crops.
- **Herbicides**, especially hormone-like weed killers such as 2,4-D, should not be stored with other pesticides (primarily insecticides and fungicides) as they can volatilize and be absorbed by other pesticides.

After freezing, place pesticides in warm storage (50°-80° F). Shake or roll container every few hours to mix product or eliminate layering. If layering persists or if all crystals do not completely dissolve, do not use product. If in doubt, call the manufacturer.



**ROBERT MARVEL  
PLASTIC MULCH, LLC**

717-838-0976  
[www.robertmarvel.com](http://www.robertmarvel.com)

## GENERAL

Look for these signs of product deterioration before using pesticides after they've been stored:

Formulation Signs of Deterioration

Emulsifiable concentrates (EC) Evidence of separation of components such as sludge or sediment. Milky appearance does not occur when water is added.

Oils Milky appearance does not occur when water is added.

Wettable powders/suspendable powders (WP, SP)

Excessive lumping; powder does not suspend in water.

Dust (D), Granular (G) Milky appearance does not occur

when water is added.

**Make arrangements to dispose of unwanted or unusable pesticides.** In Pennsylvania, contact your regional Department of Agriculture office for information on the ChemSweep pesticide disposal program or go to [https://www.agriculture.pa.gov/Plants\\_Land\\_Water/PlantIndustry/health-safety/environmental-programs/Pages/default.aspx](https://www.agriculture.pa.gov/Plants_Land_Water/PlantIndustry/health-safety/environmental-programs/Pages/default.aspx).

*Ms. McKeag is with the Univ. of Massachusetts Vegetable Program.*

*From the **Vegetable Notes for Vegetable Farmers in Massachusetts**, Univ. of Mass. Extension, Vol. 34, No. 24, November 10, 2024.*

# MaterMacc Precision Vacuum Planters Finally, One Planter For All Seed!

## New PushMacc

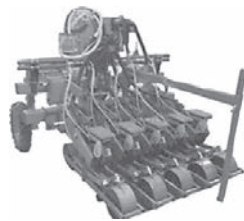

## VegiMacc

### WE ALSO STOCK:

- Transplanters • Rototillers • Sprayers
- Cultivators Bed Shapers • Mulch Layers
- Spading Machines • Veg. Harvesters
- Wash Lines • Potato Diggers

## Bean Harvester



3 Point Hitch  
with Adjustable  
Hydraulic Offset



## MaterMacc

Two row shown with **Easy Set Toolbar** and **Stainless Steel** fertilizer and insecticide hoppers. **Plants All Size Seed** from Raw Lettuce to Pumpkin!  
**Quick Change Row Spacings!**  
**Quick Change Seed Variety!**  
**Quick Fertilizer Clean Outs!**  
**1.5 Thimble Seed Charging!**  
**Ideal for Corn & Pumpkin!**

SOLD BY:

**Market Farm Implement, Inc.**

257 Fawn Hollow Road • Friedens PA 15541

**814-443-1931** | [www.MarketFarm.com](http://www.MarketFarm.com)

• VISITORS BY APPOINTMENT •

**CLASSIFIEDS****Supplies**

**FOR SALE - New Produce Boxes** – 2,000 broccoli and 2,000 cauliflower boxes.  
Call 717-615-8986

**Equipment**

**FOR SALE - Four 24' x 400' Haygrove High Tunnels** – gutter-connected - \$20,000 or best offer (30% of new price)  
Call 484-512-0381

**Classified Ads and  
Sale Notices are free for  
PVGA members for  
non-commercial sales.**

Call us at 717-694-3596  
or email us at [pvga@pvga.org](mailto:pvga@pvga.org).

**PIRRUNG?**



# PVGA FULL COLOR AD

**MEMBERSHIP & CONVENTION**

**PVGA Membership and Mid-Atlantic Fruit & Vegetable Convention Registration Form**

Name \_\_\_\_\_  
 Farm Name \_\_\_\_\_  
 Address \_\_\_\_\_  
 City/State \_\_\_\_\_ Zip Code \_\_\_\_\_  
 PA County \_\_\_\_\_ Telephone \_\_\_\_\_/\_\_\_\_\_/\_\_\_\_\_ Cell Phone \_\_\_\_\_/\_\_\_\_\_/\_\_\_\_\_  
 Facsimile \_\_\_\_\_/\_\_\_\_\_/\_\_\_\_\_ Electronic Mail \_\_\_\_\_

**Business Information** Please check all that apply.  
 Grower (owner-operator)  Retail  Wholesale  
 Fresh Market Vegetables  Processing Vegetables  Greenhouse Vegetables  Potatoes  
 Small Fruit  Bedding Plants  Cut Flowers  Tree Fruit  Wine Grapes  
 Grower Employee  Supplier (equipment, chemicals, etc.)  Processor  Other \_\_\_\_\_

**2022 PVGA Membership Dues**

**Regular Membership** Dues increase to \$75 after February 5. \$70.00 \_\_\_\_\_  
 Open to all owner, operators and employees of vegetable, potato and berry farm operations, processing firms and supply companies. All memberships include newsletter subscription.

**Associate Regular Membership** Includes newsletter subscription. \$40.00 \_\_\_\_\_  
 Must be one of the following - circle one: Student Retired University Staff Extension Agt.

**Keystone Membership** An optional membership category open to vegetable and berry farming operations, processing firms, and supplier firms. Includes newsletter subscription.

Dues based on gross income from vegetable potato or berry industries. Any member paying \$100 or more in dues will be considered a **Keystone Member**. The new winter dues are only suggested.  
 \$100 for up to \$75,000 \$25 for \$75,000 to \$50,000 \$75 for \$150,000 to \$225,000  
 \$225 for \$225,000 to \$500,000 \$500 for \$500,000 to \$1,000,000 \$1,000 for over \$1,000,000

**Associate Keystone Membership** Must be a family member or employee of a Keystone Member. \$40.00 \_\_\_\_\_

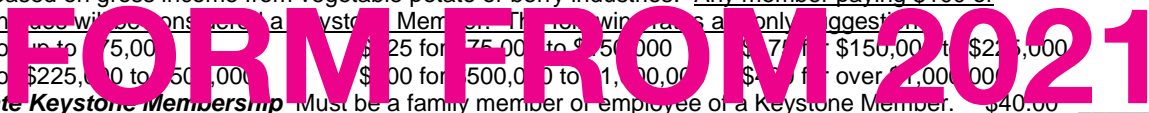

**2022 Mid-Atlantic Fruit and Vegetable Convention**

**REGISTRATION IS REQUIRED FOR EACH PERSON, including spouses.** Registration fees allow one to attend both fruit and vegetable sessions as well as enter the exhibit area. Each registrant also receives a copy of the Proceedings. Students and children 16 and under receive free registration. No refunds of pre-registration fees will be made unless canceled by January 28 in writing, by phone (717-694-3596) or by email (pvga@pvga.org). No confirmation will be mailed prior to the Convention.

**PLEASE LIST THE NAME OF EACH PERSON ATTENDING**

(for use in preparing nametags – CIRCLE ANY PERSONS WHO WILL BE ATTENDING THE SPANISH SESSION)

**Member Registration** one fee whether you are attending for 1, 2 or 3 days - per person

Advance for the first person from a family, farm or business (\$90 after Jan. 28) @ \$75.00 \_\_\_\_\_

Advance for additional persons from a family, farm or business (\$90 after Jan 28) @ \$60.00 \_\_\_\_\_

**Non - Member Registration** - (family and employees of PVGA members will be admitted at the above member's rates.)

One Day per person @ \$125.00 \_\_\_\_\_

Three Day includes registration for 2 or 3 days per person. @ \$165.00 \_\_\_\_\_

**Student /Children Registration** for students and children 16 and under only @ no charge \_\_\_\_\_

**Workshops/Tour** **PRE-REGISTRATION IS REQUIRED FOR THESE EVENTS** please indicate who will be attending below

Basic Floriculture Greenhouse – Jan 31 (with lunch) names \_\_\_\_\_ @ \$65.00 \_\_\_\_\_

Hemp Prod. – Jan 31 (with lunch) names \_\_\_\_\_ @ \$50.00 \_\_\_\_\_

Farm Transition – Jan. 31 (with lunch) names \_\_\_\_\_ @ \$50.00 \_\_\_\_\_

FSMA Grower Training - Jan 31 (with lunch) names \_\_\_\_\_ @ \$35.00 \_\_\_\_\_

PA Pesticide App Training – Jan 31 (with lunch) names \_\_\_\_\_ @ \$65.00 \_\_\_\_\_

Conducting and Analyzing On-Farm Research – Jan. 31 (no lunch) \_\_\_\_\_ @ \$20.00 \_\_\_\_\_

Farm Market Bus Tour – Jan. 31 (with lunch) names \_\_\_\_\_ @ \$70.00 \_\_\_\_\_

**Meals** Annual Growers Dinner – February 1 @ \$35.00 \_\_\_\_\_

**Proceedings** Registration includes a free copy (\$15 if picked up at the Convention) @ \$20.00 \_\_\_\_\_

**Country Folks Grower** -Check here to receive a free monthly subscription to this publication \_\_\_\_\_

**Total Enclosed** Payment by check or money order only - make checks payable to "PVGA" \_\_\_\_\_

Mail this registration form and payment to: **PVGA, 815 Middle Road, Richfield, PA 17086-9205** 717-694-3596 - phone and fax



**Pennsylvania Vegetable Growers Association**

815 Middle Road  
Richfield, Pennsylvania 17086-9205  
717-694-3596  
pvga@pvga.org  
www.pvga.org

*Change Service Requested*



PRESORTED STANDARD  
U.S. POSTAGE  
**PAID**  
HARRISBURG PA  
PERMIT NO. 533



# OUTSTANDING SEED COMPANY, LLC<sup>®</sup>

B R E E D E R | P R O D U C E R

**NEW  
FOR  
2023**

Outstanding Seed is dedicated to innovation and exceptionalism in breeding, production, and sales of stacking pumpkin, specialty pumpkin, jack-o'-lantern, and mini pumpkin hybrids.

Over fifty hybrids are available to meet many different needs. Call today to place an order or request our 2023 Catalog.

## **Corn Cob F1**

- Hard shell fruit are heavily covered with large warts.
- Unique beautiful bright caramel color.
- Average weight is 10 pounds.
- Moderate Powdery mildew resistance.
- FarMore<sup>®</sup> treated seed and untreated seed are both available.

P.O. Box 1584 | Beaver Falls, PA 15010 | 800.385.9254 | [www.outstandingseed.com](http://www.outstandingseed.com)