

PENNSYLVANIA
VEGETABLE GROWERS

NEWS

October & November 2023 / Volume 46 Number 10 & 11

for the commercial vegetable, potato and berry grower

2024

MID-ATLANTIC *fruit & vegetable convention*

JANUARY 30–FEBRUARY 1, 2024

HERSHEY LODGE
Hershey, Pennsylvania

www.mafvc.org

Plan Now to Attend this Year's Convention!

The 2024 Mid-Atlantic Fruit and Vegetable Convention will be held at the Hershey Lodge from January 30 to February 1. Multiple concurrent educational sessions will be featured all three days along with a large industry trade show. Eric Finkenbinder, award-winning meteorologist at abc27, will be this year's keynote speaker. A Berks and Lancaster Counties farm market bus tour and several pre-convention workshops will be offered on January 29, 2024. The Convention is also honored to be hosting the annual meeting of the North American Strawberry Growers Association with growers coming from all over the continent.

Normally over 2,200 fruit, vegetable, and berry growers and other industry personnel from throughout the mid-Atlantic region and beyond gather each year for what has become one of the premier grower meetings on the East Coast. The 2024 Conven-

tion will be the 47th annual gathering of growers at the Hershey Lodge in Hershey, Pennsylvania.

Plans are being made to offer exceptional educational sessions on a full range of topics in tree fruit, vegetable, small fruit, and potato production plus retail and wholesale marketing. With the North American Strawberry Growers joining this year's meeting, there will be a special emphasis on strawberry production. Greenhouse ornamental and cut flower sessions plus sessions on urban agriculture will be included as well. Also offered will be special sessions presented in Spanish for Spanish-speaking industry members. A more detailed schedule with topics and speakers will be announced soon on the Convention website at www.mafvc.org.

The day before the main Convention opens, growers can

continued on page 8

NEWS



*Pennsylvania
Vegetable Growers
Association*

*An association of
commercial vegetable,
potato and berry growers.*

President

Rita Resick '26
Somerset

First Vice President

Peter Flynn '24
West Chester

Second Vice President

Tina Forry '25
Palmyra

Secretary-Treasurer

William Reynolds '25
Waynesboro

Past President

Brian Campbell '24
Berwick

Directors

Christopher Harner '26
State College

Barron Hetherington '25

Ringtown

Alan Kemmerer '25

Berwick

Arthur King '24

Valencia

Amy Metrick '24

Butler

Michael Orzolek '24

State College

James Reiff '26

Leola

John Shenk '26

Lititz

Robert Shenot '25

Wexford

Jeffrey Stoltzfus '26

Atglen

Jonathan Strite '25

Harrisburg

Mark Troyer '24

Waterford

Joel Weaver '26

Windber

Executive Director

William Troxell
Richfield

Deputy Executive Director

Tammy K. Linn
Harrisburg

PVGA Annual Meeting

The Annual Meeting of the General Membership of the Association will be held on January 31, 2024, at 11:30 a.m. in the Crystal Room of the Hershey Lodge in Hershey, Pennsylvania. Members will receive reports from the officers and various committees as well as the announcement of

the results from the mail-in ballots for the Board of Directors. They will also vote on additions to the Association's Policy Resolutions which state PVGA's position on various issues of the day. All members are urged to attend this meeting.

We Need Your Help at the Farm Show!

Each year over 200 PVGA members and friends volunteer at the PVGA Food Booth at the Pennsylvania Farm Show in Harrisburg. We need at least 20 or more volunteers in the booth at all the times. Since the Farm Show runs from 8:00 a.m. to 9:00 p.m., we need two shifts to completely cover each day from January 6 to 13, 2024. That translates into a lot of volunteer hours. Plus, we will again be open the afternoon of the previous Friday, January 5, from noon to 9:00 p.m.

You say you don't come to the Farm Show? Why not break tradition and come for once? It's worth the trip just to volunteer your time to the Association and any farmer is bound to see at

least a few things of interest at the Farm Show. There is a wide array of exhibits throughout the Complex. Are you really too busy in the middle of the winter to take a day off to help support vegetable and small fruit research? In 2023 we earned a record profit of over \$100,000. The Farm Show Booth profits have helped enable the Association to contribute \$1.4 million to research over the past 35 years.

We are grateful to the many PVGA members who help out each year but we need new volunteers each year. If YOU have never helped before, PLEASE call us today at 717-694-3596 and volunteer for 2024. You'll be helping your Association besides having an enjoyable time.

Hired Agricultural Youth Work Guidelines Published

There are many benefits to adolescents working in agriculture, but there also are risks, especially when youth are assigned jobs beyond their capabilities. Since 2009, more youth have died working in agriculture than in all other industries combined.

The just-published Hired Agricultural Youth Work Guidelines (HAYWG) (<https://cultivatesafety.org/hired-youth/>) are designed to help farm employers and supervisors of hired youth reduce

the risk of injury for young workers. HAYWG includes guidance for training and supervising young workers, information on regulations and tip sheets for supervising youth performing common farm tasks. Adults can use this resource in tandem with the Agricultural Youth Work Guidelines (AYWG) <https://cultivatesafety.org/safety-guidelines-search/?category=familyyouth->, which help them assign age- and ability-appropriate tasks to youth.

The **Pennsylvania Vegetable Growers News** is the official monthly publication of the

Pennsylvania Vegetable Growers Association, Inc.,

908 North Second Street, Harrisburg, PA 17102

Phone and fax: 717-973-5915 • Email: pvga@pvga.org • Website: www.pvga.org

Our Mission:

The Pennsylvania Vegetable Growers Association serves Pennsylvania's commercial vegetable, potato and berry growers through education, research, advocacy and promotion.

Our Vision:

The Pennsylvania Vegetable Growers Association will be the driving force in ensuring the future viability of the commercial vegetable, potato and berry industries in Pennsylvania.

Inquiries about membership, this publication or advertising rates should be directed to Tammy K. Linn, Executive Director, at the above address.



PVGA Membership - A Bargain Too Good to Pass Up!

Nearly 2,600 people who are not members of PVGA will be receiving this Special Convention Issue of the Pennsylvania Vegetable Growers News compliments of PVGA. We want you to join our Association. We're putting our best foot forward by inviting you to the 2024 Mid-Atlantic Fruit and Vegetable Convention and by giving you the opportunity to see a copy of our newsletter. Together they represent the key educational opportunities the Association offers to its members. And member education is one of the primary missions of the Association.

We believe one of the best ways to see the vegetable, potato and berries industries of Pennsylvania prosper is to have growers who are knowledgeable and up-to-date in their production and marketing practices. Therefore, we have worked hard to offer one of the most comprehensive educational programs for growers on the East Coast at the Mid-Atlantic Fruit and Vegetable Convention. In addition, each month the Pennsylvania Vegetable Growers News provides PVGA members with valuable information on current issues affecting growers as well practical production information from experts at Penn State and other universities. Each week, members with email receive the PVGA Update with links to news and event announcements online. PVGA also usually sponsors local grower twilight meetings and farm market tours to allow growers to visit fellow growers' farms and markets in person during the growing season.

A \$70 annual membership in PVGA brings you this newsletter as well as subscriptions to the American Vegetable Grower magazine and the Vegetable Growers News. That's a hard bargain to beat but, wait, there's more!!!

Through the efforts of PVGA volunteers at the Association's booth at the Farm Show and from profits from the Convention, the Association is usually able to contribute \$55 to \$70 or more per member to vegetable and small fruit research. Even during 2021, when Association income was about half of the normal amount, PVGA was able to contribute \$80 per member using General Fund reserves that had been built up over the years cover such an unexpected drop in income. We are proud to be able to help our industry stay on the cutting-edge of technology. Over the past 35 years, PVGA has given over \$1.4 million to research.

PVGA is the organized voice of the vegetable, potato and berry industries in the Commonwealth and works to represent your interests in Harrisburg and Washington. Consequently, when legislation that affects the industry is considered, the industry has an organized voice ready to protect your interests.

PVGA owns the trademark for the "Pennsylvania Simply Sweet" onion to provide Pennsylvania growers with the opportunity to market a branded crop at a premium price.

You, if you are involved in the vegetable, potato or berry industries in Pennsylvania (or nearby states), can be a part of the PVGA team by joining today. Until February 5, dues are only \$70 – a real bargain. Use the form on page 34 to join PVGA for 2024.

If you are currently a PVGA member, it is especially important to renew your membership for 2024.

NEWS

Program Promotes PA Veggies to Millions in 2023



The Pennsylvania Vegetable Marketing and Research Program once again actively promoted PA Veggies reaching millions of Pennsylvania consumers. Last year the Program introduced the theme “Summer Means Local! Local Means Delicious” to broaden the reach of the Program’s promotion efforts beyond the “August is PA Produce Month” promotions. One of the most successful parts of this year’s promotion efforts was a digital advertising campaign supported by a Specialty Crop Block Grant from USDA through the PA Dept. of Agriculture.

Using paid online advertisements, the Program generated 2.7 million impressions from Pennsylvania viewers and drove nearly 60,000 to the Program’s website. Of those views, 43,000 visitors used the Program’s directories to find local farm markets, community farmers’ markets, CSAs, wholesale growers or produce auctions.

Taste Profit Marketing, the Program’s marketing partner, worked to update and enhance the PAVeggies.org website for consumers. They produced original blog posts as well as a seasonal chart coloring page, vegetable storage guide and numerous social

media graphics. A new recipe brochure and seasonal availability chart was also created.

On the website three “lead magnets” were added to encourage almost 1,000 consumers to sign up for the Program’s consumer email series. These new subscribers were added to the Program’s previous email subscribers and received a series of emails with tips about PA Produce throughout the season. The new subscribers automatically received a series of welcome emails to highlight PA Produce. Another series of emails were sent to growers to inform them about resources available from the Program.

The Program continued its social media campaign by posting regularly on Facebook and Instagram creating over 400,000 impressions. Several videos and reels on Instagram were viewed by another 18,000 persons.

The Program continued to supply growers with point-of-purchase materials including price cards, price paddles, price stickers, “How-to-Use” information cards, roadside signs, banners, and brochures as well as tee-shirts, aprons and hats – all with the “PA Produce” logo.

Marketing and Research Board Hires New Executive Secretary

The Pennsylvania Vegetable Marketing and Research Program Board met on November 6 and finalized a contract with Allison Brown to serve as the Program’s new Executive Secretary. Ms. Brown will be working with the Program’s current Executive Secretary until he retires at the end of year. The Board had agreed to contract with Ms. Brown at a special meeting in September but finalize the contract at its November meeting. The Board also elected officers for 2024, met with researchers to review research pre-proposals, discussed promotion plans for 2024 and adopted a budget for the next year.

Ms. Brown is a horticulture marketing specialist who has done extensive work as an international value chain expert and a program evaluator. She has a long history of work on local food systems, farmer-to-consumer direct marketing, gardening for nutrition and risk reduction. She has published scholarly papers on regional and local food systems, particularly farmers markets and small volume produce auctions. Ms. Brown holds a Master of Agriculture degree from Penn State and has held positions at the University of Arizona, University of Massachusetts, Asian Network for Sustainable Ag. and Bioresources in Nepal, and Penn State. Much of her work has been conducted internationally and she speaks several languages besides English. She is a native of Lewistown, Pennsylvania, and operates consulting firm, Tuscarora International.

The Board re-elected its current officers which are Christopher Powell of Strasburg as the Chair, Scott Hoffman of Northumberland as the Vice Chair and Kenneth Metrick of Butler as the

Secretary-Treasurer. The Program Board is made up of 12 growers appointed by the PA Secretary of Agriculture, a sales agent representative and a representative of the Secretary although currently there are five vacant seats on the Board. The Department is working filling these vacancies.

The Board, along with some representatives from PVGA on the joint Vegetable Research Committee, reviewed nine research pre-proposals with researchers who attended the meeting virtually. They then determined which pre-proposals they were most interested in seeing full-proposals for at their January 31 meeting.

They also reviewed the promotion activities of the past year, again with some representatives of PVGA on the joint Vegetable Marketing Committee. Ada Broussard, from the Board’s marketing consultant Taste Profit Marketing, then reviewed the plans for 2024 under the Specialty Crop Block Grant (SCBG) project which the Program was awarded that will support continued digital advertising, social media campaigns and other activities in 2024.

Finally, they adopted a tentative 2024 budget that anticipates \$193,735 in income and \$217,785 in expenses. It anticipates \$30,000 in research contributions from PVGA and allocates an additional \$31,350 from the Program’s funds for a total of \$71,350 for research. It also provides \$107,635 for vegetable promotion including \$83,635 for the SCBG project. The Program will be also be receiving a \$5,000 matching grant from the state Department of Agriculture.



PLANT. PICK. PROFIT.

**BETTER GENETICS. BETTER PRODUCTIVITY.
BETTER PROFITABILITY.**

new



INSPIRATION

78 Day Bicolor Sh2 Sweet Corn

Inspiration is a mid to late bicolor that is flexible in its marketing slot as a roadside stand and a shipping variety. Look to Inspiration to have the seedling vigor, high yield and great taste the grower and customer rely upon.

HR: Ps (RpGFJ), MDMV
IR: Et



EASTERN CROWN

59 Day Broccoli

This heat tolerant, early maturing variety holds in the field extremely well and will keep its nice dark green color in hot weather. Eastern Crown is the best choice for those wanting to combine heat tolerance with wide adaptability.

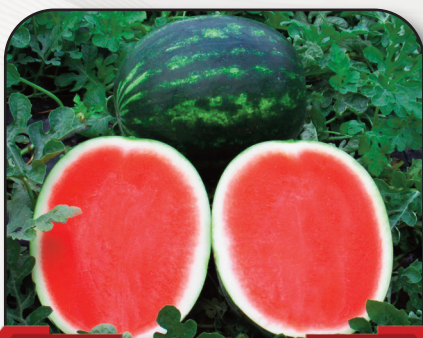

CRACKERJACK

80-82 Day Triploid Seedless Watermelon

Consistent yields over wide range of growing conditions. Very uniform fruit shape, firm flesh and deep red interior. Time and time again customers rate this our best tasting watermelon.

13-17 lbs. IR: Co:1, Fon:1



SNOW DROP

100 Day White Pumpkin

A stunning baby white pumpkin! Fruit is smaller than Snowball in size with a bright white color that holds well in the field. Prolific, generally sets 8 fruit/plant. 1-2 lbs.

(800) 952-7333

www.seedway.com

NEWS

In Memory**Thomas G. Ford**

Thomas G. Ford, 63, of Duncansville, passed away Tuesday, surrounded by his family at UPMC Altoona. He was born in Washington D.C., son of the late James and Julia (O'Brien) Ford. He married Laura Levering in 1986 in Westminster, Maryland.

Tom graduated from South Carroll High School in 1978, then earned a BS in Horticulture from the Univ. of Maryland, and earned a MBA in Business Administration from Frostburg State University. Tom was a Commercial Horticulture Educator for 41 years, most recently at Penn

State Univ. for the last 31 years.

He has been very involved in planning the educational program for the Mid-Atlantic Fruit and Vegetable Convention for many years, organizing workshops and various sessions. He also wrote numerous articles that appeared in the PVGA newsletter and worked closely with the growers in the south central part of the state. He an outstanding Extension Educator and will be solely missed by growers.

Before falling ill, he was a member of St. Patrick Church in Newry. Tom enjoyed taking trips with his wife and spending time with his family.

Surviving are his wife of 37 years; four sons: Sean and wife Faith of Ebensburg, Zachary of Hollidaysburg, Andrew and girlfriend, Gracynn of Duncansville, Kevin and girlfriend, Becca of Hershey; a grandson, Arlo; sisters: Mary Naill, Kathy Levering, Dottie Pumputis, Julie Bolin, and Theresa Bethune.

Adapted from the Carroll County Times, Dec. 7, 2023.

In Memory**Harvey S. Sauder**

Harvey S. Sauder, 76, of New Holland, passed away on November 25, 2023 in his residence.

Born on the family farm, he was the son of the late John M. Sauder and Katie (Snyder) Sauder Noit.

He was the husband of Grace I. (Weber) Sauder, with whom he shared 58 years of marriage.

He attended Hahnstown United Zion Church and was employed at Tyson Foods for 26 years. He had also

previously worked for Kings Potato Chips and was a farmer his whole life. A long-time PVGA member and strawberry grower, he and his wife regularly attended PVGA tours and field days as well as the Convention.

Harvey is survived by his wife, Grace and his children; Lois (William) Pfautz of Ephrata, Donna (Edmund) O'Brassill of Ephrata, John (Lena) Sauder of Dundee, NY, Melvin Sauder of New Holland, Brenda (Evan) Martin of Ephrata, David (Rachel) Sauder of Lima, OH, Eunice (Barry) Wenger of Denver and Sarah (Amos) Hoover of Rock Stream, NY. Also surviving are 36 grandchildren, 27 great grandchildren and sisters; Ruth (Jody) Ansel, Irene Haas and Esther (Francis) McGill.

In addition to his parents, he is preceded in death by a sister; Alta Sauder.

The family would like to give thanks to Hospice for All Seasons, especially Michy, Tammy, Joyce, Nicole, Coryn and Chaplain Rick.

In lieu of flowers, memorial contributions may be made to the Hahnstown United Zion Church at 1031 Valley View Rd, New Holland, PA 17557.

C. Stanley Eckenroth Home for Funerals in Terre Hill was entrusted with the funeral arrangements.

lambert

PREMIUM PROFESSIONAL PEAT-BASED SUBSTRATES



FOR ALL YOUR GERMINATION AND ALL PURPOSE NEEDS



DENNIS DOBROWSHSKI

Cell: (484) 716-5662

Toll Free: (888) 632-8808

lambertpeatmoss@aol.com

www.lambertpeatmoss.com



NEWS

In Memory Brian Dale Pallman



Brian Dale Pallman, 73, of S. Abington Twp., passed peacefully Friday morning at home, surrounded by his family, following a courageous battle with pancreatic cancer. He was the loving husband of the former Carolyn Jane Catanzarite for over 53 years.

Born in Scranton, son of the late Arthur "Dutch" and Leona Pallman, he was the co-owner/operator of Pallman Farms alongside his two brothers, Rich & Bruce.

Brian lived his life centered around 4 loves; faith, family, friends, and farm. He treasured his time on the farm working alongside his father Dutch, brothers Rich and Bruce, son Doug, and nephew Craig. Brian enjoyed his travels to Canada, Bellingham, WA and Mercyhurst University with his wife Jane. When not working, Brian could be found enjoying his boat or attending countless sporting events and dance recitals for his grandchildren, who were his greatest joys in life. Brian had the ability to touch the

lives of many due to his warm and welcoming nature. His friends will remember him for being the person to rely on when in need.

Brian was a graduate of Abington Heights High School, class of 1967. He was a life-long member of the Pennsylvania Vegetable Growers Association and a regular PVGA Farm Show Food Booth volunteer, a Lackawanna/Wyoming County Farm Bureau member, and a recipient of the Pennsylvania Master Farmers Award in 1988.

Surviving are his daughter Tracy and partner, Colin, Bellingham, WA; son Douglas and wife, Felicia, Newton Twp.; six cherished grandchildren: Zach, Skylar, Hannah, Harper, Hadley, & Hensley; two brothers, Richard and wife, Sylvia, Newton Twp., and Bruce, his identical twin and lifelong best friend, and wife, Debra, Clarks Summit; a sister, Betsy Jayne and husband, William, Newton Twp.; brother-in-law Frank Catanzarite and wife, Barb, Indianapolis, IN; sister-in-law Teresa Pagani and husband, Fred, Newton Square; along with many nieces and nephews.

A special thank you to Dr. Michael Kondash, Dr. Kristin Liptock, the doctors at NYU Langone Health, Rachel Masters with Traditional Home Health, and the staff at Sacred Heart Hospice, who were all instrumental in the care of Brian.

In lieu of flowers, the family would request support to end pancreatic cancer. In the Spring, Brian's loved ones plan to walk under the team Brian's Turkey Trot. Contributions can be made at https://secure.pancan.org/site/TR/PurpleStride/PurpleStride?team_id=51826&pg=team&fr_id=2810

ingham, WA and Mercyhurst University with his wife Jane. When not working, Brian could be found enjoying his boat or attending countless sporting events and dance recitals for his grandchildren, who were his greatest joys in life. Brian had the ability to touch the

ProducePackaging.com[®]
for all your produce packaging needs

1-800-644-8729
Kurt Zuhlke & Assoc., Inc.
P.O. Box 609, Bangor, PA 18013



Over 45 Years In The Industry

For over 45 years, Kurt Zuhlke & Assoc., Inc. has been a part of the many innovative packaging concepts utilized by the produce industry.

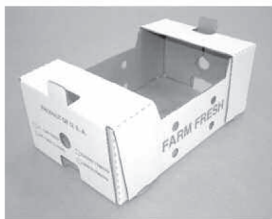

High Quality Products And Services

Our packaging is designed to protect produce, provide excellent visibility to the consumer, reduce shrinkage and enhance the product. We also offer professional labeling design and application.



From Farmers To Repackers

Whether you are ordering a case or a truck load, you can rest assured that we have the ability and capacity to service your orders quickly.



NEWS

Plan Now to Attend this Year's Convention! continued from page 1



Keynote Speaker

Eric lives in Perry County, Pennsylvania, where he enjoys most of his time on the family farm or in his backyard working on one of his many hobbies. His time on the farm showed him the importance of detailed, local weather forecasts which is why he pursued meteorology at Penn State. He received a B.S. in meteorology in 2003 and started working at his hometown news station. This will be Eric's 21st year with abc27 where you can see him during the weekday evening newscasts at 5, 6, 7 and 11 p.m. Eric also provides science and agriculture stories for the station and writes a weather outlook for Lancaster Farming, a weekly regional newspaper.

When he is not forecasting or working in the fields, Eric enjoys learning new ways to improve his vegetable and fruit gardens, beekeeping, forest regeneration projects, helping his daughters with 4-H projects, or perhaps learning another new hobby. He is a member of the Capital Area Beekeepers Association and American Chestnut Foundation.

choose between a bus tour of farm markets in Berks and Lancaster Counties or several different workshops. The workshops include Maximizing Strawberry Productivity, Producing Vegetable Transplants, Software Solutions for Farm Management, Sustainable High Tunnel Production, Recall Readiness, An Overview of the Farm Transition Process, Specialty Mushrooms, FSMA Grower Training and Pennsylvania Pesticide Applicator License Training. The bus tour will be visiting Reiff's Farm Market in Ephrata, Brecknock Orchards in Mohnnton, Weaver's Orchard in Morgan-

town and Plum Creek Farm Market and Creamery in Bernville.

On the opening day of the Convention, besides the keynote presentation by Eric Finkenbinder, there will be production sessions on High Tunnels, Tree Fruit, Strawberries, General Vegetables, Urban Agriculture, Herbs, Cut Flowers, Irrigation Automation/Technology, and Nut Trees plus marketing sessions on Farm Market Management, Creative Marketing, and Wholesale Marketing.

Sessions on the second day include Tomatoes, Tree Fruit, Strawberries, Stone Fruit, General Vegetables, Greenhouse Ornamentals, General Small Fruit, and Organic Vegetable Production plus Marketing 101 and Agritourism marketing sessions and two Labor/Farm Management sessions which will focus on H-2A issues. Also offered will be the session "Técnicas de Producción de Frutas y Hortalizas" especially for Spanish speaking workers in the fruit and vegetable industries. It will feature various relevant production presentations in Spanish.

On the final day of the Convention, sessions on Tree Fruit, Stone Fruit, Small Fruit, Pumpkins, Potatoes, Wildlife Damage Control, General Vegetables, Soil Health/Cover Crops, Post Harvest Handling, Hydroponic Vegetables, Innovative Marketing and High Value Niche Crops and Social Media and Digital Marketing will be featured.

The Mid-Atlantic Convention has been jointly sponsored by the State Horticultural Association of Pennsylvania, the Pennsylvania Vegetable Growers Association, the Maryland State Horticultural Society and the New Jersey State Horticultural Society since 1978. In 2014, the Virginia State Horticultural Society also began meeting at the Convention. Extension personnel from Penn State, University of Maryland, Rutgers and Virginia Tech all assist in organizing the three days of educational sessions.

The Great American Hall and the Aztec Room at the Hershey Lodge will host most of the Trade Show with several additional booths being located in the Confection Level Lobby. Specialized horticultural equipment, farm market merchandise, and packaging will all be on display along with information on the latest seed varieties, fruit varieties, pesticides and other supplies and services for the commercial grower.

Many pesticide applicator update training credits will be available to Pennsylvania, Maryland, New Jersey and Virginia

continued on page 11

Pre-Convention Workshops – January 29

Lancaster – Berks County Farm Market Bus Tour

Producing Vegetable Transplants

Sustainable High Tunnel Production

Recall Readiness

Begin with an End in Mind: An Overview of the Farm Transition Process

Specialty Mushrooms

Maximizing Productivity: Strawberry Production

Software Solutions for Farm Management

FSMA Grower Training

PA Pesticide Applicator License Training



BIOPESTICIDES WITHOUT COMPROMISE

Protect your vegetables with the dynamic trio of Cueva, Double Nickel, and LifeGard.

Cueva®

LIQUID COPPER FUNGICIDE CONCENTRATE

1. Low-load liquid copper formulation
2. Smaller particle size provides better coverage and longer residual than other coppers.
3. Great performance on bacterial spot & speck, black rot, and powdery mildew.
4. OMRI-listed
5. 4-hr. REI, 0-day PHI

Double Nickel®

BIOFUNGICIDE

1. High-potency Bacillus strain with multiple modes of action against fungal and bacterial diseases.
2. Soil applications improve root establishment, protect against pathogens like Rhizoctonia, and enhance yield.
3. Foliar applications defend against bacterial and fungal diseases like early blight, bacterial spot and speck, and powdery mildew.
4. OMRI-listed
5. 4-hr. REI, 0-day PHI

LifeGard®

BIOLOGICAL PLANT ACTIVATOR

1. Activates the natural defense mechanism in your crops before infection takes hold.
2. Excellent rotation partner against a wide variety of bacterial and fungal diseases.
3. OMRI-listed
4. 4-hr. REI, 0-day PHI



CERTIS
Biologicals



CERTISBIO.COM | 1-800-250-5024

©2022 Certis USA

Judy Collier

(302) 542-4665

jcollier@certisbio.com

MID-ATLANTIC *fruit & vegetable convention*

Berks and Lancaster Counties Pre-Convention Bus Tour

Monday, January 29, 2024

7:45 a.m. — 5:30 p.m.

Cost is \$95 and includes lunch. Departure and return is from the Hershey Lodge Chocolate Lobby.



Reiff's Farm Market – Ephrata, PA. Reiff's Farm Market is a second-generation family-owned farm and greenhouse business. They grow over 40 different varieties of peaches, nectarines, and plums in a 12-acre orchard, 30 acres of sweet corn, and 8 acres of potatoes, pumpkins, and strawberries on their 60-acre farm. These crops stock the market, along with produce from nearby growers. The farm market includes a bakery. A 15,000-square-foot greenhouse rounds out the farm market's offerings.



Weaver's Orchard – Morgantown, PA. Weaver's Orchard is a 4th generation family farm. Customers can enjoy time harvesting their many pick-your-own crops or browse the farm market which offers a wide range of items including fresh produce, value-added items, local cheeses and other dairy products, and free-range meats. The farm market features a bakery, full-service deli, and café, plus a garden center. Weaver's Orchard offers educational experiences, events and tours for the public, as well as serving as a venue for private parties. www.weaversorchard.com/

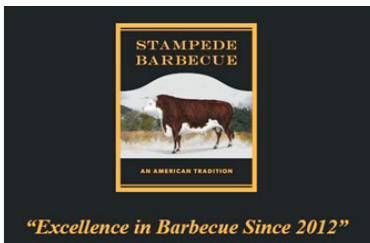

Lunch: Stampede Barbecue – Mohnton, PA. Highly recommended by our local tour hosts. Stampede is opening their restaurant on the day of the tour just for our group, so we'll be able to enjoy some quality time together while we enjoy a buffet of hot items on a winter day. Lunch will feature a choice of meats, sides and desserts. stampedebarbecue.com



Brecknock Orchard – Mohnton, PA. Brecknock Orchard provides opportunities to create memories, pick your own fruit, vegetables and flowers, enjoy family fun festivals and farm tours, and taste highlighted product samples in the farm market. Our goal is to serve others with the blessings we are given, offering the highest quality and selection of goodness from our orchard. Tour attendees will learn about our vision and values, and how we provide a "Wow" customer experience with positive culture that involves the entire team. Hear about our experiences in diverse products, marketing, technology, service, events, and group tours. www.brecknockorchard.com/



Plum Creek Farm Market & Creamery – Bernville, PA. This operation started as a roadside stand just west of Reading, selling fruits and vegetables from their farm. The roadside stand quickly grew to become a bakery, cafe, and ice cream shop. At the end of 2022, they built a pretzel factory and started wholesaling their famous soft pretzels. God has taken them on a memorable journey from selling produce on a small roadside wagon to where they are today. www.plumcreekfarmmarket.com

PRE-REGISTRATION IS REQUIRED. REGISTER WITH THE GROUP OF YOUR CHOICE AT :

WWW.MAFVC.ORG/REGISTRATION

For more information, visit www.mafvc.org or call 717-677-4184 or 717-973-5915



CONVENTION

Plan Now to Attend this Year's Convention! *continued from page 8*

growers attending the sessions. Arrangements are also being made to offer respirator-fit tests for pesticide applicators. The program covers nearly every aspect of fruit, vegetable, potato and berry production. Commercial growers should not pass up this terrific educational opportunity. Just as important, however, is the opportunity to network with fellow growers and others in the industry. Many growers feel that is the most important part of the Convention.

The seventeenth annual Mid-Atlantic Cider Contest will be conducted during the Convention to determine the best tasting cider produced in the region. On January 30, fruit and vegetable growers will gather for the annual Fruit and Vegetable Growers Banquet which will include awards and recognitions. On January 31, there will be an Ice Cream Social for all in the evening plus a reception for apple growers. There will also be roundtable discussions on Retail Farm Marketing and Why We Farm – Faith and Family.

Registration is required for all persons attending the Convention trade show or educational sessions. Registration with any of the five sponsoring organizations allows one to attend any of the sessions although there are additional charges for workshops and meals.

The Convention is not all business however. It is a wonderful opportunity to take a short vacation in ChocolateTown, USA, "The Sweetest Place on Earth," with fellow vegetable and fruit growers.

The Hershey Lodge is the ideal place for you to be January 30 to February 1, 2024. Take advantage of the special reduced room rate of \$169 (plus 11% taxes) in effect for the Convention. To make a room reservation, call 1-855-729-3108 and ask for the Mid-Atlantic Fruit and Vegetable Convention block or go the "Lodging" page on the Convention website at www.mafvc.org. Be sure to make your reservation as soon as possible to guarantee receiving the discounted rate.

Whether you stay overnight or not, it will be well worth your while to drive to Hershey, even if you just stay for the day. Pennsylvania growers need to be informed about the newest and best in their industry and most of us could use some reminding about the basics or some fresh inspiration from the success of others – or lessons from their failures!

The 2024 Convention program continues our standard of a world-class grower educational meeting. So do yourself a favor and make a sound investment in your business by attending the 2024 Mid-Atlantic Convention.

Please let us know about your plans. Advance registration can save you money and exempt you from waiting in a registration line.

We hope to see you in Hershey. If you can't make to Hershey, you can still order a copy of the Proceedings so you won't miss out on the educational opportunities of the Convention.



ELEANOR

An early to mid watermelon with high yield potential, high stress tolerance, high Brix, deep red flesh and delicious flavor for a satisfying eating experience.



ADONIS

A strong vining variety that produces tall attractive barrel shaped fruit with nice ribbing and a long, thick firmly attached Harris Moran handle.



OLYMPUS

A legendary orange carver that delivers reliable yields and the unique ability to consistently set in the Southeast. Grows on a strong vine for a well adapted crop.



BARTRAM

An adaptable bean that works well in warmer planting slots. Produces consistent yields on an open plant with caps and stems for freshness.

Discover more about our vegetable seed varieties by visiting our website:
www.hmclause.com



COMMUNICATIONS DIVISION | US8235 | 1123

CONVENTION

2024 Pre-Convention Workshops

The following pre-convention workshops and bus tour will be offered on Monday, January 29, 2024:

Producing Vegetable Transplants - Crystal Room

\$70 includes lunch
9:00 am - 4:00 pm

Have you considered growing your own vegetable transplants? Or maybe you would like to brush-up on the fundamentals? Participate in this pre-convention workshop where you'll learn from growers, industry, and Extension personnel about topics important to healthy transplants. Learn the basics like water, heat, potting soil, and disease control to more specialized education on equipment, seed treatments, and specific crop and equipment advice from three reputable Pennsylvania growers. Whether you're getting started in producing transplants or desire to improve your current system, this workshop is sure to improve your skills.

- 9:00 **Equipment Used to Start Transplants** – David King, Harvest Valley Farm
- 9:45 **Heating the Greenhouse** - Ben Beiler, DS Stoves
- 10:15 **Soil Media** - Dustin Frey, Frey Brothers, Inc
- 11:00 **Seed Treatments with Hot Water Demo** - Glen Bupp, Penn State Extension
- 11:30 **Container, Nutrients** - Dr. Gordon Johnson, Univ. of Delaware Extension (retired)
- 12:15 **Lunch**
- 1:00 **Watering Techniques, Hardening Off** - Dr. Gordon Johnson, Univ. of Delaware Extension (retired)

- 1:30 **Disease Control** - Joanne Lutz, Griffin Greenhouse Supplies
- 2:15 **Break**
- 2:30 **Growing Tomato Transplants** - Jonathan Martin
- 3:00 **Growing Cucurbit Seedlings Especially Seedless Watermelon** - David Miller, Miller Plant Farm

04 Sustainable High Tunnel Vegetable Production - Magnolia Room AB

\$70 includes lunch and educational materials
9:00 am - 4:30 pm.

This full-day workshop featuring several highly qualified academic and industry experts will offer a unique opportunity to deepen your knowledge on novel sustainable high tunnel technologies and crop management solutions. The workshop has been designed to address the needs of both beginning and advanced high tunnel growers, technicians, students, and professionals and will cover a series of aspects considered critical for the short- and long-term sustainability and profitability of high tunnel production systems. Topics covered include: a) high tunnel construction, siting and feature considerations for adequate temperature and crop ventilation management; b) soil health and sustainable management of soilborne pests and pathogens; c) ways to include cover crops in the crop rotation and benefit from their multiple functions; c) organic amendment, nutrient management and in-season crop monitoring for the rationale fertigation of conventional and organic high tunnel crops; d) cucumber and other profitable crops alternative to fresh-market tomatoes and

continued on page 14

Since 2001 Authority in Refrigeration for Agro-Industrial Applications in North America.

PLUG AND PLAY  **FREE COOLING**

- Thru the Wall 
- Portable 
- Roof Mounted 
- Hydrocoolers
- Custom Designs
- Blast Freezers
- Chillers
- Greenhouse Coolers 

ENERGY Efficient

1.866.748.7786
info@kooljet.com



- > Pistol grip spray gun
- > Tee-Jet 6B control valve
- > Pressure regulator
- > Jet agitation
- > Calibration disc

Produced by:
Martin's Repair Shop LLC
27 W Mohler Church Rd. Ste 1
Ephrata, PA 17522
717-733-3015

See a video of the ATX and MRS units in operation at
https://www.youtube.com/watch?v=2CGn_Bhcxs8



RUPP FEATURE:

Carbonado Gold is a 100-day, very uniform 40 count pumpkin. Dark orange with black handles makes this an industry standard.



OCTANE

Octane is extremely tender and sweet.

Matures in 78 days, but this variety will hold onto the stalk for an extended time.



PINK DELICIOUS

Pink Delicious is a modern tomato with a heirloom look.

This crack-resistant hybrid titan will keep customers returning to your roadside market.

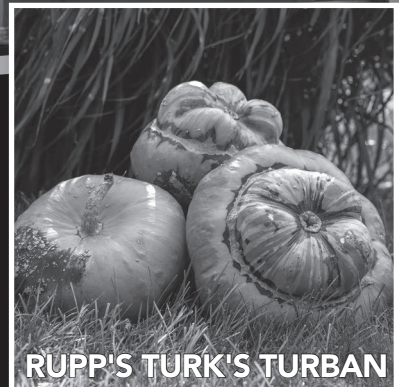

RUPP'S TURK'S TURBAN

Rupp's Turk's Turban is one large turban.

This 110-day turban weighs between 15-25 pounds. Orange with green and white.

Visit our booth at the 2024 Mid-Atlantic Fruit and Vegetable Convention!

More than 1,000 seed varieties at ruppseeds.com

Questions/Orders: 1-800-700-1199



RAISING THE BAR
IN QUALITY, FLAVOR, & YIELD

CONVENTION

2024 Pre-Convention Workshops continued from page 12

lettuce, and best crop rotation strategies for year-round production; e) variety selection for different vegetable high tunnel crops with general recommendations and specific suggestions; f) novel technologies and solutions for spraying in high tunnels and their calibration; g) proactive crop disease management, and g) bio-control solutions for pest management in high tunnel crops. The workshop will be highly interactive with Q&A (question and answer) and discussion session after each presentation. Lunch and coffee break will offer the opportunity to establish a contact and network with speakers, industry professionals, other attendees, and representatives of the companies sponsoring the workshop. The workshop includes at least one presentation that will provide Pesticide Core Credits.

- 8:30 **Registration**
 9:00 **High Tunnel Construction, Siting, and Feature Considerations for Adequate Temperature and Crop Ventilation Management** – Dr. Matthew Kleinhenz, Ohio State Univ.
 9:45 **Soil Health and Sustainable Management of Soil-borne Pest and Pathogens** – Dr. Francesco Di Gioia and Joe Ono Raphael, Penn State
 10:30 **Cover Crops in High Tunnels** – Dr. Annette Wszelaki, Univ. of Tennessee
 11:00 **Developing Integrated Nutrient Management to Enhance Organic Vegetable Production in High Tunnels** – Prof. Xin Zhao, Univ. of Florida
 11:45 **In-season Monitoring and Nutrient Management via Fertigation** – Dr. Francesco Di Gioia, Penn State
 12:15 **Lunch Break and Sponsor Presentation**
 1:00 **Variety Selection in High Tunnels: General Strategies & Specific Suggestions** – Dr. Becky Sideman, Univ. of New Hampshire

- 1:45 **Cucumber High Tunnel Production** – Dr. Wenjing Guan, Purdue Univ.
 2:30 **Beyond Tomatoes and Lettuce: Crop Rotations to Maximize Profit and Minimize Soil Issues** – Dr. Annette Wszelaki, Univ. of Tennessee
 3:00 ***Proactive Vegetable Crop Disease Management in High Tunnel** – Steve Bogash, ProFarm
 3:30 ****Biocontrol Solutions for the Management of Key Pests in High Tunnel** – Carol Gleinster, IPM Lab (Pesticide core credit)

Begin with the End in Mind: An Overview of the Farm Transition Process - Empire Room CD

\$25 (no lunch)

9:00 am – 12:00 pm

Join the Penn State Extension Farm Transition Team for this half-day workshop. We will focus on the vital components needed to ensure your farm transitions in the manner and to the people you desire. All farm and ag business owners and operators of all levels are welcome.

- 9:00 **Business and Retirement Planning** – Jodi Gauker & Paula Ledney, Penn State Extension
 10:00 **Transition and Estate Planning** – Samantha Gehrett, Penn State Extension, & Brook Duer, Penn State Center for Ag and Shale Law
 11:00 **Case Study and Questions** – Entire Farm Transition Team
 12:00 **Adjourn**

continued on page 15

Refrigerated and Ventilated Cooling Systems for Fruit and Vegetable Storages

- COMMERCIAL REFRIGERATION
- DESIGN, SALES AND SERVICE
- SERVING AGRICULTURE FOR OVER 70 YEARS

Free Consultation and Quote
 Call Mike Mager at 585-343-2678

See Us At
 Booth #78 At
 The Mid-Atlantic
 Fruit & Vegetable
 Convention

ARCTIC

REFRIGERATION CO. OF BATAVIA
 26 Cedar Street, Batavia, NY 14020
www.arcticrefrigeration.com

TEW MANUFACTURING CORP.

Fruit & Vegetable Cleaning & Sizing Equipment & Parts

Quality Latex & Poly Sponge Rubber Drying Donuts

Tuff Foam® Protective Padding

Brushes • Bearings • Sizing Chains

Belting • Scrubber Rubber

New Stainless Steel Machines

**CALL TOLL FREE 800-380-5839
 FOR CATALOG & PRICES**

TEW MFG. CORP.
 P.O. BOX 87
 PENFIELD, NY 14526

585-586-6120
 FAX: 585-586-6083
www.tewmfg.com

CONVENTION

2024 Pre-Convention Workshops *continued from page 14*

Recall Readiness - Empire Room AB

\$75 includes lunch

9:00 am - 3:00 pm

Food recalls happen -- even to good farms/companies - and being prepared is the best way to minimize their financial and reputational damage while also protecting public health. Join us for this interactive discussion and tabletop exercise during which you and your fellow attendees will navigate typical food recall decisions, regulatory requirements, and communication demands. And if your farm/company has a written recall plan, bring it so you can take notes, ask the facilitator plan-specific questions, and make real-time updates throughout the session. The presenters will be Amy Philpott, founder of Philpott PR Solutions LLC and Emily Moyer of the International Fresh Produce Association.

Specialty Mushrooms - Cocoa Suite 6

\$35 (no lunch included)

12:00 pm - 4:30 pm

Mushrooms are an increasingly popular commodity with customers. However, there are many different specialty species and considerations for adding mushrooms as a crop. If you have been thinking about growing mushrooms, developing a new niche, or generating creative revenue streams off your land, this workshop may help get you to the next step. The workshop will include an in-depth overview of specialty mushrooms and considerations for successfully cultivating popular species. At the end of the workshop, specialty mushroom growers from Pennsylvania and Maryland will offer their practical experience and knowledge as part of a grower's roundtable.

- 12:00 **An Overview of Specialty Mushrooms** – Dr. John Pecchia, Penn State Univ.
- 1:00 **Getting Started with Producing Specialty Mushrooms** – Dr. John Pecchia, Penn State
- 2:00 **Break**

- 2:30 **Quiet Creek Herb Farm & School of Country Living: An Overview of Shitake Mushroom Production** - Sylvia Rensel, Quiet Creek Herb Farm

- 3:30 **Grower Round Table** - Kyle Beaver, Ten Mile Mushrooms; Matt Sicher, Primordia Mushroom Farm; and Courtney Cohen, Spore and Seed

A discussion of the practical aspects of starting a specialty mushroom farm or diversifying your farm production with mushrooms

Maximizing Productivity: Strawberry Production Workshop - Cocoa Terrace/Cocoa 1

\$80 - includes lunch

9:00 am - 4:30 pm

Strawberry production A-Z will be covered, starting with factors to consider before planting such as soil health and site preparation, production systems including matted-row, plasticulture, and indoor production, fertility, varieties, and insect, disease and weed management. Marvin Pritts from Cornell University, and David Handley from the University of Maine will be the presenters. Workshop presented by the North American Strawberry Growers Association.

- 9:00 Welcome, introduction to workshop (Marvin Pritts and David Handley)
- 9:10 Understanding the Strawberry Plant, 20 min (Marvin or David)
- 9:30 Factors to consider before planting (labor, local climate, site, how you want to market), 30 min (Marvin or David)
- 10:00 Soil health, site preparation, crop rotations (30 min) (Marvin Pritts)
- 10:30 Break 15 min
- 10:45 Fertility and nutrient management (30 min) (Marvin Pritts)
- 11:15 Varieties: Cool climate performance (20 min) (David Handley)

continued on page 16

Two Locations to Serve You Better!



Nolt's Greenhouse Supplies

Specializing in Greenhouse and Nursery Growing Supplies

(717) 354-8376

151 E. Farmersville Road
Ephrata, PA 17522



Nolt's Produce Supplies, LLC

Specializing in Vegetable Growing Supplies and Equipment

(717) 656-9764

152 N. Hershey Avenue
Leola, PA 17540



Compact Raised Bed Mulch Layer



Greenhouses & High Tunnels



Hyd Reset Mulch Lifter



Hyd Drive Wrapper



Water Wheel Transplanter

Please contact us for our free commercial growers catalogs or view it on our website: www.noltsproucesupplies.net

CONVENTION

2024 Pre-Convention Workshops *continued from page 15*

- 11:35 Varieties: Warm climate performance (20 min) (Jayesh Samtani)
- 11:55 Open discussion on morning topics
- 12:05 Lunch
- 1:00 Matted row production and variants, including weed mgt (50 min) (David Handley)
- 1:50 Plasticulture and variants: Zones 6 and Cooler (25 min) (Marvin Pritts)
- 2:15 Plasticulture and variants: Zones 7 and Warmer (25 min) (Jayesh Samtani)
- 2:40 Break 10 min
- 2:50 Insect and Disease Mgt (1 hour) David Handley
- 3:50 Alternative systems (greenhouse, substrate production) (30 min) Marvin Pritts
- 4:20 Open discussion on afternoon topics

Software Solutions for Farm Management (Young Grower Alliance) - Empire Room CD

\$15 no lunch included
2:00 pm - 4:00 pm

This workshop is meant to highlight software used by growers and available from industry professionals that make modern farming easier. This includes programs like a pesticide spray program manager, weather station data collection, and more. There will be several highlights of programs available commercially as well as a grower panel discussing efforts made by growers to use non-commercial programs to improve their farms and farm-stand operations.

Food Safety Modernization Act Grower Training - Wild Rose Room

\$50 includes lunch
9:00 am - 4:30 pm

This training is for fruit and vegetable growers and others interested in learning about: produce safety, the Food Safety Modernization Act (FSMA) Produce Safety Rule, Good Agricultural Practices (GAPs), and co-management of natural resources and food safety. This PSA course is one way to satisfy the grower training requirement of the FSMA Produce Safety Rule

as outlined in Section 112.22(c). Participants in the course will learn about:

- Microorganisms relevant to produce safety and where they may be found on the farm;
- How to identify microbial risks, practices that reduce risks, and how to implement produce safety practices on the farm;
- Requirements in the FSMA Produce Safety Rule and how to meet them.

After attending the entire course, participants will be eligible to receive a certificate from the Association of Food and Drug Officials (AFDO) that verifies they have completed the training course. The Pennsylvania Food Safety Resource Center is providing funds to cover AFDO certification fees and course material costs for this workshop.

Pennsylvania Pesticide Applicators License Training - Magnolia Room D

\$85 includes lunch and manual
9:00 am - 4:00 pm

If you intend to purchase and/or apply restricted use pesticides for the purpose of producing an agricultural commodity on land which is owned or rented by you, then you need a Pennsylvania Department of Agriculture Pesticide License. To become a certified private applicator, testing is required. This full day session on January 29 will cover the basics and prepare you for the pesticide applicator's exam which will take place the next morning, January 30, from 8:30 a.m. – 11:30 a.m.

09 Farm Market Bus Tour

\$95 includes lunch
Buses depart the Hershey Lodge Chocolate Lobby at 7:45 am and will return at about 5:30 pm
See details on page 10.

Hillside Cultivator Co. LLC



Hydraulic adjusted cultivator
for the edges of plastic mulch



Cultivators especially for
Strawberries



Eco Weeder for close cultivation
around individual plants

For more information visit hillsidecultivator.com

Contact: John Shenk 717-669-3158 Lititz, PA hillsidecultivator@gmail.com



REGALIA[®]

BIOFUNGICIDE



No Regalia in transplant solution

Regalia in transplant solution 1qt./100 gal. of water

IMPROVE PLANT HEALTH FROM TRANSPLANT TO HARVEST

- ✓ Add Regalia to transplant water
- ✓ Increase root growth
- ✓ Enhance plant health & crop yield

MANAGE BLACK ROT & ALTERNARIA

JET-AG[®] 5%

Fungicide, bactericide, algacide with multiple uses & stable formula that's more effective than competition

TANK MIX WITH



Increases crop performance by stimulating plant's ability to fight diseases such as powdery mildew.



Provides broad spectrum disease control on challenging diseases such as downy mildew, Botrytis & Black Rot.

FUNGICIDES REDUCE BLACK ROT IN BRUSSELS SPROUTS

Dr. Chris Smart, Cornell University - 2018

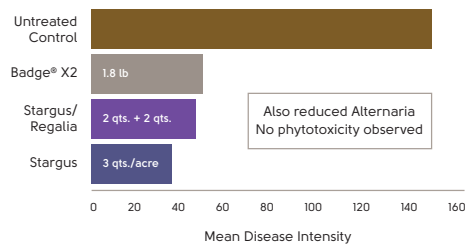

TALK TO AN EXPERT



Steve Bogash, New England, PA, NY, NJ, DE, MD, WV, VA
 p: 717-877-7105 • e: SBogash@ProFarmGroup.com



Learn more at ProFarmGroup.com

©2023 Pro Farm Group, Inc. Stargus, Jet-Ag & Regalia are all registered trademarks of Marrone Bio Innovations.

CONVENTION

2024 Mid-Atlantic Convention Educational Program

Tuesday Morning, January 30, 2024

11 Winter High Tunnel Production - Magnolia Room ABC

9:00 **Winter Spinach Production in High Tunnel** - Susan B. Scheufele, UMass Extension

9:45 **The Most Important Lessons Learned with High Tunnel Winter Production Panel** - Jen Glenister, New Morning Farm; Dr. Matthew Kleinhenz, Ohio State Univ.; Susan B Scheufele, Univ. of Massachusetts Extension; Dr. Annette Wszelaki, Univ. of Tennessee

12 Herbs - Crystal Room

9:00 **Growing and Drying Herbs Organically** - Jodi Danyo, Cherry Valley Organics

9:45 **Quiet Creek Herb Farm & School of Country Living: Making & Selling Value-Added Herbal Products** - Sylvia Rensel, Quiet Creek Herb Farm

13 Tree Nut Production - Empire Room AB

9:00 **To Be Announced**

9:45 **To Be Announced**

14 Urban Agriculture - Empire Room CD

9:00 **Intro** - Russell Thorsen, Pasa Farming

9:15 **Urban Ag Beekeeping (Part 1)** - Robyn Underwood & Jeff Eckel, Penn State Extension

9:45 **Urban Ag Beekeeping (Part 2)** - Robyn Underwood & Jeff Eckel, Penn State Extension

15 Irrigation Automation/Technology - Wild Rose Room

9:00 **Automating Your Irrigation 1** - Lee Fiocchi III, Lee Rain, Inc.

9:45 **Automating Your Irrigation 2** - Lee Fiocchi III, Lee Rain, Inc.

16 Strawberries - Trinidad Room

9:00 **Soil Health for Berry Crops** - Dr. Marvin Pritts, Cornell Univ.

9:45 **Practical Uses of Cover Crops in Strawberry Rotations** - (Marvin Pritts moderator) Charles Gray, 4Corners Farm, VT; John Shenk, Shenk Berry Farm, PA; Jay Yankey, Yankey Farms, VA

17 Farm Market Management - Cocoa Terrace/Cocoa 1

9:00 **Difference Between Markup & Margin** - Brian Moyer, Penn State Extension

9:45 **To Be Announced**

18 Tree Fruits - Nigerian Room

9:00 **Invocation** - Ed Weaver, Weaver's Orchard

9:05 **SHAP President's Address** - Andrew Schwalm, State Horticultural Association of Pennsylvania

9:15 **Goodling Lecture - Crop Load Management Using Thinners** - Todd Einhorn, Michigan State

10:00 **Research Perspective on Codling Moth and Oriental Fruit Moth Challenges** - Dr. Greg Krawczyk, Penn State

19 Keynote - Nigerian/Trinidad Room sponsored by the American Vegetable Grower and the American Fruit Grower

10:45 **General Announcements**

11:00 **Keynote Presentation - Challenges of Our Changing Local Climate** - Eric Finkenbinder, abc27

continued on page 19

Pasa SUSTAINABLE AGRICULTURE

Diversified Vegetable Apprenticeship



Apprentice Ventura Ortiz at Apple Ridge Farm, Pennsylvania

Apply today at pasafarming.org/dva

Pasa's Diversified Vegetable Apprenticeship pairs beginning farmers with established growers to provide a guided pathway toward managing or starting a vegetable farm.

Applications for host farms & apprentices are reviewed on a rolling basis, however we recommend applying by **February 25, 2024**.

Apprentices

prepare for a career in farm management and receive 2,700+ hours of paid, on-the-job training and 200+ hours of related coursework over 18 months.

Host farms

train the next generation of sustainable farmers and gain access to a pool of pre-qualified employees invested in farming as a career.

Diversified Vegetable Apprenticeship is administered in Pennsylvania and the surrounding region.



CONVENTION

2024 Mid-Atlantic Convention Educational Program *continued from page 18*

Tuesday Afternoon, January 30, 2024

21 Summer High Tunnel Production - Magnolia Room ABC
sponsored by the American Vegetable Grower

- 1:30 **High Tunnel Ventilation (Temperature) Management** - Dr. Matthew Kleinhenz, Ohio State Univ.
- 2:00 **Using Photo-selective Covering Films to Improve Green and Purple Basil Yield and Quality and Manage Downy Mildew** - Dr. Francesco Di Gioia and Kathleen Demchak, Penn State
- 2:30 **Using Grafting as an Effective Tool to Promote Organic Tomato Production: How Can We Optimize Grafting Gains?** - Dr. Xin Zhao, Univ. of Florida
- 3:15 **Automated Drip Irrigation for Pepper and Tomatoes** - Dr. Harlene Hatterman-Valenti, North Dakota State Univ.
- 4:00 ***Timber Rot Management** - Steven Bogash, ProFarm Group
- 4:30 ****Calculations and Best Practices for Mixing Small Amounts of Pesticides** - Leah Fronk, Penn State Extension

22 General Vegetables - Crystal Room

- 1:30 **Embracing Bitter Beauty: Radicchio Varieties and Their Performance in the Northeast** - Dr. Rebecca Sideman, Univ. of New Hampshire
- 2:00 **Growing Italian Vegetables from a Culinary Perspective** - Jason Oddo, Coldco Farm
- 2:30 ****Pesticide Mixing: How to Avoid Mixing Disasters** - Jamie Kopco, Penn State Pesticide Education
- 3:15 **Watermelon Production – Varieties, Grafting and Fertility** - Dr. Wenjing Guan – Purdue Univ.
- 4:00 ***What's Wrong with My Plants? Strategies for Plant Diagnosis** - Jennie Mazzone, Penn State

23 Cut Flowers - Empire Room AB

- 1:30 **More Than One Way To Sling a Flower: Cut Flower Farm Business Model Comparison** - Laura Beth Resnick, Butterbee Farm and Michelle Elston, Roots Flower Farm
- 3:15 **Cut Flower Research at USU Small Farms Lab: Key Findings for Crops, Production Systems, and Environmental Sustainability** – Dr. Melanie Stock, Utah State Univ.
- 4:00 **Evaluating Hydrangeas for Landscape and Cut Flower Use** - Dr. Rebecca Sideman, Univ. of New Hampshire

24 Urban Agriculture - Empire Room CD

- 1:30 **The Giving Grove - Urban Orchards** - Naim Edwards, Michigan State Univ.
- 2:15 **High Tunnel Rainwater Harvesting & Solar Pump System** - Raymond Balaguer, Univ. of Florida Extension
- 2:30 **Urban Soils Project in Philadelphia** - Patrick Drohan, Penn State
- 3:15 **Urban Farming Site History Assessment Tools** - Russell Thorsen, Pasa Sustainable Agriculture
- 4:00 **To Be Announced** - Kefeni Kejela, USDA

25 Success in Wholesale Marketing - Wild Rose Room

- 1:30 **Consumer Demographics and Consumer Trends of Local Foods, Direct Marketing, and Agritourism Patterns in the Mid-Atlantic Region** - Ramu Govindasamy, Rutgers Coop. Extension
- 2:00 **What's Up with the FSMA Water Rule** - Jeffrey Stoltzfus, Penn State Extension
- 3:00 **Produce Buyer Panel: Industry Trends** - Michelle Infante-Casella, Moderator
Panelists: Thomas Beaver, Sunny Valley International; Jaci Daly, Sprouts; Phil Neary, Pratt Industries

continued on page 20

Plant, Maintain And Harvest Your Produce



- Fully adjustable operator platform and head support for all day comfort
- Foot- Controlled Variable Speed and steering keeps both hands free for higher production



- :Trailer or wagon style option
- :30 ft aluminum conveyor with paddles 12in apart
- :Conveyor can be moved from front to back with track system
- :Conveyor can be lifted above bins for transporting

Give us a call or visit our website for more information

**25 Old Leacock Rd - Ronks Pa 17572
717-768-7619 | www.harvestpromfg.com**

CONVENTION

2024 Mid-Atlantic Convention Educational Program *continued from page 19*

26 Small Fruit - Trinidad Room

- 1:30 ***Weeds as Hosts of Strawberry Anthracnose: Implications for Management** – Leah Fronk, Penn State Extension
- 2:00 **USDA-ARS Strawberry Cultivars from Beltsville-2024** - Dr. Kim Lewers, USDA-ARS
- 2:30 **Understanding Runner Formation and Management** - Dr. Edward Durner, Rutgers University
- 3:15 **Greenhouse and High Tunnels: Options in Strawberry Substrate Production** - Dr. Neil Mattson, Cornell Univ. and Kathy Demchak, Penn State
- 3:45 **Greenhouse and High Tunnel Strawberry Substrate Production: Practical Experiences** - Valérie Bernier-English, Ferme Onésime Pouliot (Onésime Pouliot Farm, Quebec); Kevin Schooley for Tamberry Farm, Ontario

27 Success in Retail Marketing - Cocoa Terrace/Cocoa 1

- 1:30 **Our Retail Success Stories – A Grower Panel**
James Abma, Abma Farms, Wycoff, NJ
James Giamarese, Giamarese Farms, East Brunswick, NJ
Greg Donaldson, Donaldson Farms, Hackettstown, NJ
Rebekah Alstede-Modery, Alstede Farms, Chester NJ
- 3:15 **Adjourn**

28 Tree Fruit - Nigerian Room

sponsored by the American Fruit Grower

- 1:30 ****Worker Protection Standard - Protecting Everyone Involved in Crop Production** - Joni Davis, Penn State
- 2:00 **Grafting Tool & Grower Talk** - Jay Harper, Penn State
- 2:30 **Post-Harvest Fungi** - Johnny Castro and Dr. Kari Peter, Penn State
- 3:15 ***Post-Harvest Fungicides and Efficacy** - Johnny Castro and Dr. Kari Peter, Penn State
- 3:45 **Packing House Packer Panel** - Dr. Kari Peter, Penn State, Moderator

Tuesday Evening, January 30, 2024

Social

- 6:00 **Reception** - Chocolate Lobby (ticket required)
- 7:00 **Annual Growers Banquet** - Nigerian/Trinidad Room (ticket required)

Wednesday Morning, January 31, 2024

31 Tomatoes - Magnolia Room ABC

- 9:00 **Tomato Variety Trial Reports (The Best Tomato Varieties for PA?)** - Dr. Timothy Elkner, Penn State Extension
- 9:30 **Upcoming Virus Challenges** - Dr. Beth Gugino, Penn State
- 10:15 **Foliar Applications** - How Are They Taken Up in the Plant? - Steve Bogash, Pro Farm Group
- 11:00 **Pest Update**
- 11:30 **PVGA Annual Meeting** - Crystal Room

32 General Vegetables - Crystal Room

- 9:00 ***Peeling the Rotten Onion: Bacterial Diseases and Copper Tolerance** – Ram Neupane, Penn State
- 9:30 ****Protecting Water Resources from Pesticide Contamination** - Jamie Kopco, Penn State Pesticide Education
- 10:15 ***Vegetable Nematode Management** – George Bird, Michigan State Univ., retired
- 11:00 ***Use of Bionematicides for Nematode Management** – Catarina Roman, Penn State
- 11:30 **PVGA Annual Meeting** – Crystal Room

33 Organic Vegetable Production - Magnolia Room D

To Be Announced

34 Greenhouse Ornamentals - Empire Room AB

- 9:00 **To Be Announced** - Nick Flax, ballHort
- 9:30 **Considerations for Slow Release Fertilizer** - Dale Bradshaw, Florikan/Profile Products
- 10:15 **Best of Penn State Flower Trials** - Krystal Snyder, Penn State Extension
- 11:00 ***New and Newer Pesticides for the Greenhouse** - Thomas Ford, Penn State Extension
- 11:30 **PVGA Annual Meeting** - Crystal Room

35 Marketing 101 - Cocoa Terrace and Cocoa Suite 1

- 9:00 **Harvesting Insights: Farmers Market Pricing Project & Benchmark Study** - Brian Moyer, Penn State Extension
- 10:00 **Food Trends 2024** - Kathy Kelly, Penn State; Claudia Schmidt, Penn State

continued on page 22



3 PT. MOWER WITH ESM SICKLE BAR



3 PT. 2 ROW CULTIVATOR



FRONT MOUNTED CROP ROLLER

View Our Equipment:

i-jmanufacturing.com

10 S. New Holland Road, Suite 2, Gordonville, PA 17529

**I & J
mfg.**

(717) 442-9451



Color Labels Convey Quality

Show off your brand and demonstrate the superiority of your products

Color labels enhance your brand and instill confidence in your customers. For over three decades Texpak has been making both fully pre-printed and partially pre-printed labels for our customers, helping them add branding to their products and differentiate themselves from the competition.

In addition to labels, Texpak offers a large variety of pot stakes and other horticulture labeling supplies, all of which can be run through an inexpensive thermal transfer printer. These supplies can be used for everything from FSMA labels to product/species identification.

Our most common label solution is the partially pre-printed label. For this type of label, we will pre-print your logo and any other branding information on part of the label, leaving a section blank for you to run through our printer. This allows you to have only one label that can be used on all your products.

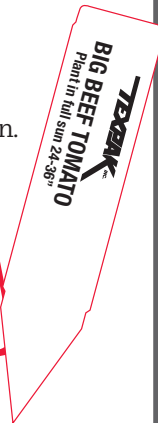
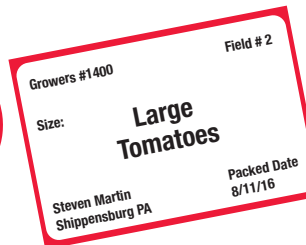
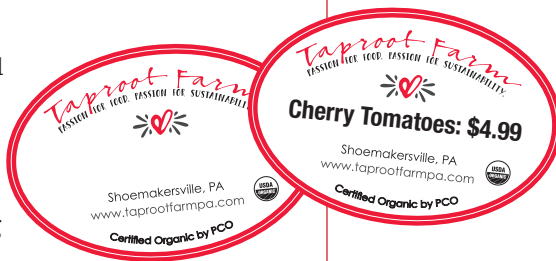

We're here to help you find the right labeling solution for you. Contact us today to speak with one of our expert sales executives.



Simple Solutions to Complicated Problems Since 1934

130 New Hyde Park Road
Franklin Square, New York 11010
info@texpak.com

800-645-3416

www.texpak.com

CONVENTION

2024 Mid-Atlantic Convention Educational Program *continued from page 20*

- 11:00 **To Be Announced** - Jason & Megan Coopey, Way Fruit Farm
 11:30 **How to Make Better Videos and Reach New Audiences** - Miranda Harple, Penn State Extension

36 Small Fruit - Trinidad Room

- 9:00 ****Optimizing Spray Coverage** - George Hamilton, Univ. of New Hampshire (emeritus)
 9:30 ***Cyclamen Mite Management with Miticides and Steam Treatment** - Dr. Justin Renkema, Agriculture and Agri-Food Canada
 10:15 **Nourse Farms: Now and in the Future** - John Place, Nourse Farms
 11:00 **Biodegradable vs. Nonbiodegradable Plastic Mulch: An Overview** - Gilles Mamame, PolyExpert, Inc.
 11:30 ***Weed Management Strategies for Strawberries** - David Handley, University of Maine
 12:00 **NASGA Annual Meeting**

37 Labor/Farm Management - Empire Room CD

To Be Announced

38 Tree Fruit - Nigerian Room

- 9:00 **Ambrosia Beetle** - Sara Villani, North Carolina State Univ.
 9:30 **Apple Lure Evaluation** - Tracy Leskey, USDA - ARS Kearneysville
 10:15 **Glomerella and Bitter Rot Control** - Sara Villani, North Carolina State Univ.

- 10:45 ***Safe and Effective Herbicide Program** - Caio Brunharo, Penn State
 11:15 **Increases in Plum Curculio in Apple and How to Control Secondary Pests** - Dr. David Biddinger, Penn State and Tracy Leskey, USDA - ARS Kearneysville

39 Spanish - Wild Rose Room

- 9:00 **Actividad de Apertura / Welcome and Ice-breaker** - Penn State Latinx Agricultural Network (LAN)
 9:30 **Poda de Arándanos/Blueberry Pruning** - Dr. Rafie Reza - Virginia Coop. Extension
 10:15 **Insectos plagas comunes en vegetales /Common Vegetable Insect Pests** - Carlos Quesada - West Virginia Univ. Extension
 11:00 **Recreo/Break**
 11:15 **Taller práctico de poda de manzanos /Apple Pruning Hands-on Workshop** - Mario Miranda Sazo, Cornell Univ.
 12:30 **Almuerzo (Catered Lunch to Celebrate 15 Years)** Penn State LAN and West Virginia Univ. Extension

Wednesday Afternoon, January 31, 2024

41 Sweet Corn - Magnolia Room ABC

sponsored by the American Vegetable Grower

- 1:30 **Outstanding Sweet Corn Cultivars** - Josh Heller, Gowen Seed
 2:00 **Corn Earworm IPM** - Dr. Thomas Kuhar, Virginia Tech

continued on page 23

Your Source for . . .

HIGH TUNNELS



RIMOL

Greenhouse Systems

Call Harry Edwards @ 717.606.8021
or Email hedwards@rimol.com

HEALTHY PREDATORS, PARASITES ON PATROL

Use Biocontrol To Stamp Out:

- Aphids
- Whiteflies
- Fungus Gnats
- Spider Mites
- Thrips

References available in your area.

“I was REALLY pleased! I didn’t see aphids [on the tomatoes] during the whole growing season.”

Vernon Weaver
McAlisterville, PA

Hearty Beneficials GUARANTEED
Call 315.497.2063



IPM Laboratories, Inc.
ipminfo@ipmlabs.com
Since 1981

www.ipmlabs.com



CONVENTION

2024 Mid-Atlantic Convention Educational Program *continued from page 22*

- 2:30 ****Conducting a Site Assessment before a Pesticide Application** - Jamie Kopco, Penn State Extension
- 3:15 **Hear from the Growers: Vital Production and Marketing Tips** - panel to be announced

42 Organic Vegetable Production - Magnolia Room D

- 1:30 **Dealing with High Soluble Salts in High Tunnels** - Veronda Blue, Penn State
- 2:00 **Soil Health and Food Safety in Organic Specialty Crop Systems - Use of Poultry Litter in Cucumber, Melon and Radish Production** - Rose Ogutu, Delaware State University
- 2:30 **Organic Bean Research** - Gladis Zinati, Rodale Institute
- 3:15 **Using Organic Nutrient Sources** - Megan Chawner and Elsa Sánchez, Penn State
- 4:00 **Maximizing Success in Organic Tomato Production** - Matt Kleinhenz, Ohio State University

43 Greenhouse Ornamentals - Crystal Room

- 1:30 ****Core Pesticide Credit To Be Announced**
- 2:00 **To Be Announced** - Nick Flax, Ball Hort
- 2:30 ***Be Your Own Plant Detective** - Steven Bogash, Pro-farm
- 3:15 **Tips on Saving Water and Fertilizers** - Neil Mattson, Cornell
- 4:00 **Evaluating the Health and Vigor of Biocontrol Agents** - Dr. Carol Glenister, IPM Labs

44 Stone Fruit - Empire Room AB

- 1:30 **Ernie Christ Lecture - PATHMAP: An Innovation in Data Management for Stone Fruit Pests and Diseases** - Dr. Wayne Jurick, USDA
- 2:00 **Peach Council Update** - Kay Rentzel, Peach Council
- 2:45 **Key Peach Pests** - Anne Nielsen, Rutgers Univ.
- 3:30 **Mating Disruption Principles: Managing Key Lepidopteran Pests in Smaller Orchards** - Laura Nixon, USDA - ARS Kearneysville

45 Agritourism - Cocoa Terrace and Cocoa Suite 1

- 1:30 **Building a Business Plan for Agritourism** - Dr. Claudia Gil Arroyo, Rutgers
- 2:00 **Pricing Agritourism Activities and Experiences** - Sarah Cornelisse, Penn State
- 2:30 **Navigating Conflicts and Building Trust** - Linda Falcone, Penn State Extension
- 3:00 **Industry Show and Tell**
- 3:15 **Building Community with Farm Events - Grower Panel**
Denise Bosworth, Rohrbach's Farm Market
Abbie Spackman, The Heirloom Farmer
Pending Speakers
- 4:00 **Making Agritourism Accessible** - Dr. Claudia Schmidt, Penn State

continued on page 24

Find us on

ROBERT MARVEL PLASTIC MULCH, LLC

Your source for all your plastic mulch and drip irrigation needs since 1974!

Mulch:
Biodegradable, Embossed, Smooth, Photo degradable, **and more.**

Products:
Drip Irrigation Tape, Floating Row covers, Greenhouse Plastic, Black Woven Ground Cover, **and more.**

Equipment:
Raised Bed Mulch Layer, Flat Bed Mulch Layer, Water Wheel Transplanter, **and more.**

Download our 2024 Product Catalog and view full descriptions of our products and more online @ www.robertmarvel.com

Contact Us!
 2425 Horseshoe Pike, Annaville, PA 17003
 717-838-0976
Info@robertmarvel.com
www.robertmarvel.com

CONVENTION

2024 Mid-Atlantic Convention Educational Program *continued from page 23***46 Small Fruit** - Trinidad Room

- 1:30 ***SWD Management: Adjuvants, Biocontrols, Repellents, and Insecticides** - Dr. Cesar Rodriguez-Saona, Rutgers Univ.
- 2:00 **Living with Extremism - No, I Mean the Weather** - Thomas Childs, Twin Spring Fruit Farm, PA with audience discussion time
- 2:30 **Living with (cont.)** - Thomas Childs, Twin Spring Fruit Farm, PA with audience discussion time
- 3:15 **Current and Future Robotics Applications in Small Fruit** - Dr. Long He, Penn State Univ.
- 4:00 **Fine-Tuning Fertilizer Applications for Small Fruit** - Mary Concklin, Raspberry Knoll Farm, CT

47 Labor/Farm Management - Empire Room CD

To Be Announced

48 Tree Fruit - Nigerian Room*sponsored by the American Fruit Grower*

- 1:30 **Rootstock Breeding Programs** - Todd Einhorn, Michigan State Univ.
- 2:00 **USDA Tree Fruit Breeding Program** - Chris Dardick, USDA - ARS Kearneysville
- 2:45 **Apples, Adapted: The University of Maryland Patents Two New Grower-Friendly Varieties** Chris Walsh, Julia Harshman, and Kathy Hunt, Univ. of Maryland
- 3:30 **Variety Showcase: Breeding for the Mid-Atlantic** - Dr. Daniel Weber, Penn State Extension

49 Spanish - Wild Rose Room

- 1:45 **Pruebas de madurez de manzanas / Apple Maturity Testing** - Dr. Macarena Farcu - Univ. of Maryland
- 2:30 **Enfermedades comunes en cucurbitas y solanáceas / Common Diseases in Cucurbits and Solanaceae** - Beth Sastre - Virginia Coop. Extension
- 3:00 **Capacitación sobre liderazgo / Leadership Training** - Carolyn Henzi Plaza and Maria Gorgo-Simcox - Penn State Extension
- 3:45 **Evaluación / Evaluation** - Maria Gorgo-Simcox - Penn State Extension

Wednesday Evening, January 31, 2024**Social**

- 5:00 **Apple Growers Reception** - Cocoa Ballroom
- 7:00 **Ice Cream Social** - Great Lobby

Roundtable Discussions - 7:00 to ?

Retail Farm Market Management
Why We Farm - Faith and Family

Thursday Morning, February 1, 2024**51 Wildlife Damage Control** - Magnolia Room ABC*sponsored by the American Vegetable Grower*

- 9:00 **Wildlife Mitigation Efforts and Game Cameras**, Steve Sample, Samples Vegetable Farm
- 9:30 **Agricultural Deer Control Programs** - Zachary Soles, Pennsylvania Game Commission
- 10:15 **How We Control Wildlife - Grower Panel** - Megan Gallagher, Be-Wilder Farm; Arthur King, Harvest Valley Farms; Jennifer Glenister, New Morning Farm
- 11:00 **How We Control Groundhogs and Raccoons** - Arthur King, Harvest Valley Farms
- 11:30 **Bird and Deer Netting** - Peter Flynn, Pete's Produce Farm; Rebecca Ryan, Oesco Inc.

52 Soil Health and Cover Crops - Crystal Room

- 9:00 **Role of OM on Soil Health and Nutrient Management** - John Spargo, Penn State
- 9:30 **Growing Soil at Braddock Farm** - Nick Lubecki, Grow Pittsburgh/Braddock Farm
- 10:00 **Industry Show and Tell**
- 10:15 **To Be Announced**
- 11:00 **To Be Announced**
- 11:30 **To Be Announced**

53 Post Harvest Handling - Wild Rose Room

- 9:00 **Post Harvest Handling and Containers** - Arthur King, Harvest Valley Farm
- 9:30 **Using Cool Bots on the Farm** - David King, Harvest Valley Farm
- 10:15 **Wash Water Management** - Andy Chamberlain, Univ. of Vermont
- 11:00 **Packing Shed Design** - Andy Chamberlain, Univ. of Vermont
- 11:30 **Managing Post Harvest Onion Quality** - Jeffrey Stoltzfus, Penn State Extension

54 Potatoes - Empire Room CD

- 9:00 **National Potato Council Update** - Kam Quarles, National Potato Council
- 9:30 **Spuds in Demand: What's Driving the Potato Market** - Kim Breshears, PotatoesUSA
- 10:15 **Soil Health and Potatoes** - George Bird, Michigan State, retired
- 11:00 **Penn State Potato Research Trials** - Xinchun Qu, Penn State
- 11:30 ****Preparing for a Pesticide Spill** - Dr. Timothy Elkner, Penn State Extension

continued on page 26



BCS

THE BEST TILLER ON EARTH
No Belts • No Chains • No Equal



PRE SEASON SALE

- 18" To 30" Tillers
- Models 7 To 13HP
- Quick Change Handle Positions
- No Time-Limit Warranty on Transmissions
- 50% Higher Tine Speed Than Competition
- Free Quick Hitch w/2+ Attachments On 732 to 853

See us at the Mid-Atlantic



Rotary Plow



Power Harrow



Brush Mowers



Sickle Bar Mowers



Snow Throwers

Also: Flail Mowers • Chipper/Shredder • Wood Splitter • Utility Trailer

WES STAUFFER EQUIPMENT LLC
www.wesstauffer.com 717-738-4215
BCS Dealer For 38 Years!

23 Pleasant Valley Rd., East of Ephrata off Rt. 322 • Mon., Wed. & Thurs., 8-5:30; Tues. & Fri., 8-7; Sat., 8-1



January 18 & 19, 2024 at Solanco Fairgrounds

Memorial Drive, Quarryville PA

More exhibitors • Larger meeting rooms

Two days of seminars and networking with fellow growers and vendors.
Food available for purchase. Breakfast, lunch and supper both days.

\$40 REGISTRATION for one or two days
\$30 Early bird registration (*before December 15*)



Workshops ★ New for 2024

- Grafting watermelon (hands on) - Limited to 30 people
- Retail store layout by: Judy Sharpton - Limited to 60 people

Additional \$30 fee to participate in a workshop - First come, first serve.
For Workshops call 717-690-1081 / For Expo Registration use the form below.

Questions? Contact the show office at 717-690-1081 or croppingexpo@gmail.com.

REGISTRATION FORM

Mail this form with payment

Date _____ Names for Badges

Business Name _____ 1. _____

Address _____ 2. _____

_____ 3. _____

Phone _____ 4. _____

PAYABLE TO: Crop Growing Expo

Early registration _____ x\$30 = _____

SEND CHECKS TO: 8126 Oakdale Rd.
Orrstown, PA 17244

Registration after Dec. 15 _____ x\$40 = _____

Total payment included = _____

CONVENTION

2024 Mid-Atlantic Convention Educational Program *continued from page 17*

55 Innovative Marketing and High Value Niche Crops - Cocoa Terrace and Cocoa Suite 1

- 9:00 **Optimizing our Farm Marketing Strategies with a Focus on Agritourism** - Tim Von Thun, Von Thun Family Farm.
- 9:30 **Selection of Hazelnut Cultivars and Pollinizers to Enhance Your Direct Market** - David Hlubik, Hlubik Farms and Rutgers Univ.
- 10:15 **What Works for Us- Our U-Pick Farm Experiences for Customers** - Stephen Specca, Specca Family Farm
- 11:00 **Winter Work: Planning, Improving and Selling in the Off Season** - James Klett, Fairgrown Farms
- 11:30 **So You Think You Want to Market to Restaurants - My Story as a Beginner Farmer** Christina Couch, Pura Farm

56 Small Fruit - Trinidad Room

- 9:00 ****Re-Tooling Your Sprayer for Better Insect and Disease Management** - George Hamilton, Univ. of New Hampshire (emeritus)
- 9:30 **Pruning Raspberries to Minimize Disease and Insect Pressure** - Dr. David Handley, Univ. of Maine
- 10:15 **Growing and Marketing Small Fruit at Raspberry Knoll Farm** - Mary Concklin, Raspberry Knoll Farm
- 11:00 **Blueberry Variety Trial Results from Southern Delaware** - Dr. Emmalea Ernest, Univ. of Delaware
- 11:30 ***Current Strawberry Disease Issues: What We're Learning** - Kathleen Demchak, Penn State

57 Stone Fruit - Empire Room AB

- 9:00 ****Fumigation PPE** - Ed Crow, Penn State
- 9:30 **Peach Varieties for the Mid-Atlantic** - Hemant Gohil, Rutgers Univ.
- 10:15 **Frost Mitigation Grower Panel** - Bill Mackintosh - Moderator, Nutrien
- 11:00 **Training Systems** - Emily Lavelly, Michigan State
- 11:30 ****Managing Pesticide Resistance** - Kara Pittman, Penn State

58 Tree Fruit - Nigerian Room

sponsored by the American Fruit Grower

- 9:00 **US Apple Update** - US Apple
- 9:30 **Unmanned Aerial Vehicle (Drone) Technologies and Applications in Tree Fruit Orchards** - Dr. Long He
- 10:15 **Reflective Ground Covers as Tools for Maximizing Apple Red Skin Coloration in the Mid-Atlantic** - Dr. Macarena Farcu, Univ. of Maryland
- 11:00 **Penn State Ag Engineering Program Projects (Robotic Precision Sprayer: Enhanced Control of Spray in Vineyards and Orchards and Robotic Green Fruit Thinning for Apple Production)** - Magni Hussein and Chenchen Kang
- 11:30 **Cold Hardiness and Dormancy** - Jason Londo, Cornell Univ.

Thursday Afternoon, February 1, 2024

61 Pumpkin - Magnolia Room ABC

- 1:30 ***Update on Some New Strategies and Insecticides for Controlling Cucumber Beetle, Squash Bug, and Aphids** - Dr. Thomas Kuhar, Virginia Tech
- 2:00 ***Are There Any New Herbicides for Use in Pumpkins?** - Dwight Lingenfelter, Penn State

- 2:45 ***Pumpkin Fungicide Trials for Managing Powdery Mildew** - Drs. Timothy Elkner and Beth Gugino, Penn State Extension and Penn State
- 3:15 **** Precautionary Statements and Washing of PPE** - Thomas Butzler, Penn State Extension

62 General Vegetable - Crystal Room

- 1:30 **Extending Lettuce Production into the Summer** - Dr. Emmalea Ernst, Univ. of Delaware
- 2:00 ***Update on Disease Control in Vegetable Crops** - Dr. Andrew Wyenandt, Rutgers Univ.
- 2:45 ***Update on Bacterial Leafspot Control in Pepper and Tomato** - Dr. Andrew Weyandant, Rutgers Univ
- 3:15 **** Precautionary Statements and Washing of PPE** - Thomas Butzler, Penn State Extension (Joint Core Session in Magnolia ABC)

63 Hydroponic Vegetables - Wild Rose Room

- 1:30 **Cucumber Bag Culture** - Thomas Childs, Twin Springs Fruit Farm
- 2:00 **Selecting Alternative Growing Media for Sustainable Soilless Crops** - Dr. Francesco Di Gioia, Penn State
- 2:45 **Resource Efficiency, Yield and Quality of Amaranth Grown as a Summer Leaf-Crop in Alternative Soilless Systems** - Pradip Poudel, Penn State
- 3:15 **Selecting a Greenhouse Lighting System** - Dr. Neil Mattson, Cornell Univ.

64 Potatoes - Empire Room CD

- 1:30 **Applying Humic Acid In-Furrow: Are There benefits?** - Jonathan Price, Sterman Masser Potatoes

continued on page 27

NOURSE
Delivering Quality

NourseFarms.com | 413-665-2658 | info@noursefarms.com

WE DELIVER
high-quality plants
so you can deliver a
high-quality
HARVEST.

SCAN TO VIEW

CONVENTION

2024 Mid-Atlantic Convention Educational Program *continued from page 17*

- 2:00 **Potato Insurance Choices for FCIC Programs** - Jon Burcham, NAU Country
- 2:45 ***Potato Insect Update** - Tom Kuhar, Virginia Tech
- 3:15 ***Sprout Control During Post Harvest Storage of Potatoes** - Emily Dobry, Penn State
- 3:45 **What PA Co-Op Potato Growers Have Accomplished** - Nathan Tallman, PA Cooperative Potato Growers, Inc.

65 Social Media/Digital Marketing - Cocoa Terrace and Cocoa Suite 1

- 1:30 **Creating Stories and Reels** - Victoria Robinson
- 2:00 **Role of SM in Responding to Crises** - Sarah Cornelisse, Penn State
- 2:45 **Streamlining Social: How to Stay Organized with Posts and Photography** - Miranda Harple, Penn State Extension
- 3:15 **Connecting with Your Audience: The Role of Emails in Modern Marketing** - Ada Broussard, Taste Profit Marketing
- 3:45 **AI and Marketing your Farm** - Shannon Dill, Univ. of Maryland

66 Small Fruit - Trinidad Room

- 1:30 ***Understanding Nematodes and Management Options in Brambles and Blueberries** - Dr. Mihail Kantor, Penn State
- 2:00 ***Blueberry Cane Diseases: Underlying Causes, ID and Management** - Dr. Peter Oudemans, Rutgers Univ.
- 2:45 **Critical Points to Know about Pruning Blueberries** - Dr. Gary Pavlis, Rutgers Univ.
- 3:15 **** Precautionary Statements and Washing of PPE** - Thomas Butzler, Penn State Extension (Joint Core Session in Magnolia ABC - lower level)

67 Labor/Farm Management - Empire Room AB
To Be Announced

68 Tree Fruit - Nigerian Room

- 1:30 **Developing Tests for Assessing Maturity** - Emily Lavelly, Michigan State
- 2:00 **Experiments Focused on Optimizing the Return Bloom and Color Intensity of Honeycrisp Apples** - Sherif Sherif, Virginia Tech
- 2:30 **Dissertation** - Shanthanu Kumar, Penn State
- 3:00 **Cider Industry Update** - Carla Snyder, Penn State Extension
- 3:30 **All Stage Fire Blight Management in High Density Apple and Pear Orchards** - Srdjan Acimovic, Virginia Tech

* denotes topics that are expected to qualify for category pesticide applicator update training credits

** denotes topics that are expected to qualify for core pesticide applicator update training credits

*** denotes topics that are expected to qualify for fumigation pesticide applicator update training credits

MECHANICAL TRANSPLANTER COMPANY

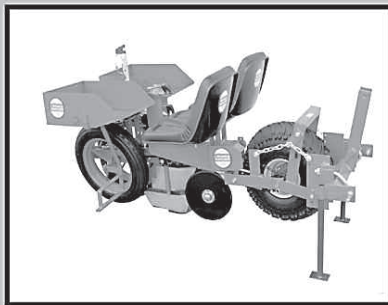

Model 1000

* Excellent for bare root and small cells. Our most popular transplanter.

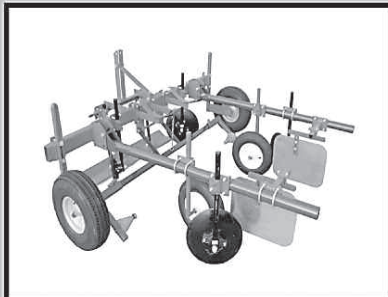

Model 90

* Lays any size mulch from 3-6 feet wide.

NEW CLEAN SEEDER



MODEL JP-1

* Excellent for small seed
* Lightweight & easy to handle
* Accurate spacing

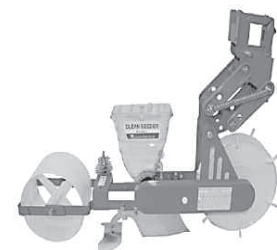

MODEL JPH

* Row spacing as close as 7"
* Mounts on 2" square toolbar

Mechanical Transplanter Company, LLC * 1150 Central Avenue * Holland, MI 49423

Phone: 616-396-8738 or 800-757-5268 * Fax: 616-396-3619

website: www.mechanicaltransplanter.com * e-mail: mtc@mechanicaltransplanter.com

CONVENTION

2024 Exhibitors

The following companies plan to exhibit at the 2023 Mid-Atlantic Convention:

Accurate Ag Drones, LLC
 Adams County Nursery, Inc.
 Advanced Ag East
 Advancing Alternatives, Inc.
 AgBiome
 Ag-Liner, Inc.
 Agri-Dynamics
 Agriteer
 AgroFresh
 Agro-K
 American National Insurance
 Arctic Refrigeration Co. of Batavia, Inc.
 Arendtsville Garage
 Atticus LLC
 Autrusa Inc.
 Avian Enterprises, LLC
 Bakie Farm Initiative LLC
 BASF
 BCS/Wes Stauffer Equipment LLC
 BDI Machinery Sales Inc.
 Bekaert Corporation
 Bowsmith Inc.
 BRANDT
 Catalytic Generators, LLC
 CBC America LLC
 Center for Schools and Communities
 Certis Biologicals
 Chester Irwin Foods, LLC
 Clifton Seed Company
 Country Folks Grower
 CropCare
 Crossroads Family of Companies
 (Cooper's Mill)
 Dillman Farm
 DuBois Agrinovation
 Durand-Wayland, Inc.
 Ebling's Service Plus LLC
 Ephrata National Bank

Farm Market Specialties
 FMC
 Farmer's Choice Foods Brands, Inc.
 Fowler's Mill
 Full Circle Mushroom Compost, LLC
 Fulton Bank
 The Gardner Pie Company
 Gowan Seed Company
 Gowan USA
 Green Star Cooperative
 Growers Equipment Center Inc.
 Growers Mineral Corp.
 Growmark FS
 H. M. Clause, Inc.
 Harris Seeds
 Harvest Pro Mfg.
 Helena Agri Enterprises
 Hillcrest Nursery Inc.
 Hillside Cultivator Co. LLC
 Honeycomb Basket
 Horizon Farm Credit
 Hybrid Seed Company
 Inter-County Bakers Inc.
 International Paper
 IPL Macro
 IPM Laboratories Inc.
 Irritec U.S.A.
 ISP Technologies
 Iva Manufacturing
 J D Associates
 Johnny's Selected Seeds
 Keystone Bio-Ag LLC
 King Orchards
 KOBA Corp.
 Kreher Enterprise
 KULT-Kress LLC
 LaGasse Machine &
 Fabrication, Inc.

Lambert Peat Moss, Inc.
 Lee Rain Inc.
 Martin's Produce Supplies
 McCutcheon Apple Products, Inc.
 Mechanical Transplanter Co.
 Meister Media Worldwide
 Messick Farm Equipment, Inc.
 Miller Chemical & Fertilizer
 Monte Package Company
 Morrissey Insurance
 New England Seed Co.
 Nichino America, Inc.
 Noble Orchards Software Solutions LLC
 Nolt's Produce Supplies LLC

Nourse Farms
 Nutrien Ag Solutions
 OESCO, Inc.
 Olde Tradition Spice, Inc.
 OMEX Agrifluids
 Orchard-Rite/Superior Wind Machines
 ORO Agri
 Otis S. Twilley Seed
 PA Department of Agriculture – Bus. &
 Risk Mgt.

continued on page 30

STAND 'N PLANT

SEEDER

Use for...

- Seeds
- Onions
- Garlic



PLANTER

Use for...

- Transplants
- Potatoes
- Bulbs



Easily plant hundreds of seeds or plants per hour into plastic covered or bare ground seed beds.

Stand 'N Plant

95 Rose Road, Saltsburg, PA 15681

Phone: 724-639-3965 or visit: www.standnplant.com



**STATEWIDE
BAG
SERVICE**
TOWER CITY, PA 17980

717-647-2623 or 717-460-7962

Visit our website at
www.tallmanpotatoes.com
 to see our full line of products

Introducing a New Product
3 lb. Brown Paper Bag
Environmentally friendly packaging Solution
100% Paper with die cut holes for ventilation.



Completely plant based, recyclable & compostable.

YOUR SOURCE FOR PRODUCE & VEGETABLE SPRAYERS

High Clearance Booms to go over Sweet Corn while High Pressure Pumps penetrate the canopy of any produce crop with up to 300 PSI



F750 70' AirRide Boom



F300 25' Single Boom



HT200 3pt 25' Single Boom

GREENHOUSE AND HIGH TUNNEL SPRAYERS

These sprayers are designed for spraying staked crops such as tomatoes and peppers. The high clearance offset axle straddles the row for minimal clearance and crop disturbance.



SEE US AT THE MID-ATLANTIC FRUIT AND VEGETABLE CONVENTION
Jan 31-Feb 1 **BOOTH 13-14**



BCS Sprayer for Staked Produce



SP50 Self-propelled Sprayer



More Info & Videos

ivamfg.com

Call us to discuss your sprayer needs. Our team can help you to get the right sprayer for your needs!

3pt and Trailer Field Sprayers



BUILDING AG SPRAYERS FOR 30 YEARS



F1000 45-75' AirRide Booms



F750 45-75' AirRide Booms



F500 35-45' SpringRide Booms



HT200 30-40' Manual Booms

(717) 768-0747 | 175 Churchtown Rd, Narvon Pa 17555 | ivamfg.com

CONVENTION

2024 Exhibitors

The following companies plan to exhibit at the 2023 Mid-Atlantic Convention: continued from page 28

| | | |
|---|--|----------------------------|
| PA Department of Agriculture – Bureau of Food Safety | Sakata Seed America, Inc. | USDA NASS |
| PA Preferred Program | San Agrow | Valent USA |
| PA Office of Rural Health – Penn State Univ. | Saunders Brothers Inc. | Valente Pasta |
| PCA | Saylor’s Farm & Crate LLC | Van Well Nursery Inc. |
| PDM Insurance Agency, Inc. | Seedway, LLC | Verdesian Life Sciences |
| Peach Ridge Orchard Supply, Inc. | Shawnee Canning Company Inc. | Vestaron Corporation |
| Penns Creek Welding | Signs of the Seasons | Victory Packaging |
| Pennsylvania Farm Bureau | Slimline Manufacturing | Wafler Nursery |
| Pennsylvania Service & Supply Inc. | D S Smith | Walker Bros. Inc. |
| Phil Brown Welding Corp. | Stauffer Huling Farms | Warner Packaging |
| Phoenix Labor Consultants | Stokes Blueberry Farms & Nursery, Inc. | Weller Insurance |
| PolyExpert | Stokes Seeds Inc. | Willow Drive Nursery, Inc. |
| Pro Farm Group | Stoller | Willsie Equipment |
| ProFence LLC | Summit Tree Sales, Inc. | |
| ProducePackaging.com | Tallman Family Farms LLC | |
| Provide Agro Corporation | Tew Mfg. Corp. | |
| Quality Fresh LLC | Texpak, Inc. | |
| Re-Divined | Thunderbird Plastics Ltd. | |
| Ridge Quest Inc. | Tilmor | |
| Robert Marvel Plastic Mulch LLC | Timac Agro USA | |
| Rockford Package Supply | Toro Ag Irrigation | |
| Rovensa Next | TRICKL-EEZ Irrigation Inc. | |
| Rupp Seeds Inc. | UPL | |
| | USDA NRCS | |

Convention Proceedings

If you cannot attend the Convention, you can purchase a copy of the Proceedings which contains summaries of many of the vegetable, small fruit, greenhouse and marketing presentations. Use the form on page 34.

Convention Lodging

Plan to stay at the Hershey Lodge and take advantage of the special convention rate of \$169 (per room per night plus taxes). Call the Lodge at 1-855-729-3108 and tell them you are attending the Mid-Atlantic Fruit and Vegetable Convention.

Or you can make reservations online at www.mafvc.org/Lodging.

CONVENTION



~ Quality Seed Since 1881 ~

Stokes Seeds
 Pennsylvania
 Seed Consultants



ASK US ABOUT OUR FULL LINE OF COMMERCIAL VEGETABLE SEED!

Contact **Tom Pagels** and **Steve Stout** for the highest quality seed and service.

609-703-5082
 sstout@stokeseeds.com

609-247-7140
 tpagels@stokeseeds.com

T: 1-800-962-4999 | www.stokeseeds.com | 13031 Reflections Dr Holland MI 49424

Penn State Offering FSMA Training Courses

The Food Safety Modernization Act(FSMA) is the most comprehensive change to produce farming in the past 70 years. Farms with less than \$28,000 in gross sales are not covered under this Act. Also growers who exclusively grow crops not normally consumed raw like potatoes, pumpkins, and sweet corn, for example are not covered by FSMA

One of the requirements of the law is that all growers covered under the Act attend a Grower Training Course. Participants will receive a notebook and receive a certificate of attendance. The cost is \$35 per grower. The course will cover seven hours of instruction time that will be spent on the following modules:

- Introduction to Produce Safety
- Worker Health, Hygiene, and Training
- Soil Amendments
- Wildlife, Domesticated Animals, and Land Use
- Agricultural Water (Part 1: Production Water and Part 2: Postharvest Water)
- Postharvest Handling and Sanitation
- How to Develop a Farm Food Safety Plan

After attending the entire course, participants will be eligible to receive a certificate from the Association of Food and Drug Officials verifying that they have completed the training.

Dates and Locations:

- January 16, 2024, Madisonburg, 8:00 a.m.
- February 29, 2024, New Holland, 8:00 a.m.
- March 12, 2024, Clarion, 8:00 a.m.
- March 15, 2024, Greensburg, 8:00 a.m.
- March 25, 2024, Oxford, 8:00 a.m.

To register for the above trainings, please visit <http://extension.psu.edu/fsma-grower-training> or call 1-877-345-0691. Checks, credit cards, and debit cards

are accepted.

Penn State will also be offering this training on Monday, January 29, 2024, at the Mid-Atlantic Fruit and Vegetable Convention, at the Hershey Lodge in Hershey. The cost for this training is \$50. To register for the training at the Mid Atlantic Fruit and Vegetable Conference, please call 717-973-5915.

Please direct any questions about the program to Jeff Stoltz-fus at 717-394-6851.

**SEE VIDEOS OF SPRAYERS IN ACTION ON UPDATED WEBSITE!
 NEW HYDRAULIC FOLD SPRAYER FEATURES
 AIRBAG BOOM SUSPENSION!**



200, 300 & 400 Gal. Manual Fold • 300 & 400 Gal. Hyd. Fold

Ask us about the advantages of the front mount boom.

PENNS CREEK MFG.

1340 Broadway Rd., Winfield, PA 17889

570-444-6500

www.pennscreekwelding.com

BUILDERS OF DEPENDABLE ECONOMICAL VEGETABLE SPRAYERS

NEWS

Crop Insurance for Specialty and Organic Crops Grow as Options Improve and Expand

The U.S. Department of Agriculture (USDA) is beefing up crop insurance options for specialty crop and organic producers, including rolling out new and expanded options based on feedback from America's agricultural producers. To achieve this, USDA's Risk Management Agency (RMA) accelerated its outreach efforts to hear directly from producers across the country by hosting in-person and virtual roadshows and making investments in risk management education.

From 1990 to 2022, liabilities for insured specialty crops rose from \$1 billion to more than \$23 billion. Over the past 20 years, the number of individual specialty crops insured under crop insurance programs increased by 27%. Currently, there are over 70 individual specialty crops insured under crop insurance programs.

New Insurance Options

Transitional and Organic Grower Assistance Program (TOGA): For 2022, RMA offered this new program reduce a producer's overall crop insurance premium bill allowing them to continue using organic agricultural systems. Premium benefits for TOGA included: 10 percentage points of premium subsidy for all crops in transition, \$5 per acre premium benefit for certified organic grain and feed crops, and 10 percentage points of premium subsidy for all Whole-Farm Revenue Protection (WFRP) policies covering any number of crops in transition to organic or crops with the certified organic practice.

Tropical Storm Coverage: For crop year 2023 and succeeding years, RMA added a new option to Hurricane Insurance Protection – Wind Index (HIP-WI) for named tropical storm weather events. The Tropical Storm Option covers damage caused by strong weather systems not categorized as hurricanes. Both a wind and precipitation trigger must occur for an indemnity to be paid. This new option helped many producers recover after Hurricane Idalia this year. About 60% of eligible policies elected this option.

Controlled Environment: Beginning in crop year 2024, producers can insure plants produced in a controlled environment against disease that occurs in their facility. This program will provide the following benefits: simple application and policy renewal process, like the Nursery Value Select program, and insurance for controlled environment producer-selected plant categories. In addition to specialty crop and organic producers, this policy will greatly benefit urban producers.

Improved Insurance Options

Whole-Farm Revenue Protection Program (WFRP): Several improvements will begin in the 2024 policy year including: allowing all eligible producers to qualify for 80% and 85% coverage levels; allowing producers to purchase catastrophic coverage level policies for individual crops with WFRP; expanding yield history to a 10-year maximum (from four years) for all crops not covered by another federal crop insurance policy; making the policy more affordable for single commodity producers; and allowing producers to customize their coverage by choosing whether WFRP will consider other federal crop insurance policies as primary insurance when calculating premium and revenue to count during claim time.

Micro Farm: Several updates were made to Micro Farm including: moving the sales closing date to a less busy time of year to help agents dedicate time to marketing the program, allowing producers to purchase other federal crop insurance with Micro Farm, allowing vertically integrated entities to be eligible and making the Expanding Operations feature available.

Quality Loss Option (QLO): RMA is making the QLO available to several initial specialty crops, including avocados (California only), blueberries, cranberries, grapes, peaches, stone fruit, and table grapes. RMA plans to make the option available to additional specialty crops in the upcoming months after further review.

More Information

Specialty crop producers can learn more on RMA's Specialty Crop Page or by contacting one of RMA's specialty crop liaisons, who serve as points of contact for local specialty crop producers. Organic producers can learn more at RMA's Organic webpage. Producers can receive the most up to date information about RMA insurance options for specialty crops by subscribing to GovDelivery.

Crop insurance is sold and delivered solely through private crop insurance agents. A list of crop insurance agents is available at all USDA Service Centers and online at the RMA agent locator. Learn more about crop insurance and the modern farm safety net at rma.usda.gov or by contacting your RMA Regional Office. To learn more, visit usda.gov

Opportunities for Farmers to Receive Free Legal Services from the Penn State Law Rural Economic Development Clinic

The Penn State Law Rural Economic Development Clinic provides law students with practical legal experience in the food and agricultural sectors. Working under the close supervision of law faculty and staff attorneys who are licensed Pennsylvania attorneys, student attorneys can assist farmers and agricultural businesses in a variety of legal matters.

The Rural Economic Development Clinic is now accepting applications for its Fall 2023 semester and is looking to assist farmers and agricultural businesses who are engaged in agritourism operations or the direct sale of agricultural products. To take advantage of this opportunity, interested individuals and organizations should send an email to Ross Pifer at rhp102@psu.edu providing a detailed explanation of the specific legal services desired along with appropriate background information. Priority will be given to those applications received by October 10, 2023. The Clinic may not be able to provide services to all who request, but we will do our best to serve the greatest number of clients possible - consistent with our resources and the legal expertise of the student attorneys.

Any questions regarding the Rural Economic Development Clinic can be directed to Ross Pifer at rhp102@psu.edu

VEGETABLE FARM EQUIPMENT
AUCTION SPECIALISTS
PIRRUNG AUCTIONEERS, INC.

JAMES P. PIRRUNG

www.pirrunginc.com

585-728-2520

*"Serving the Buying - Selling Needs of Farmers
Across America Since 1948"*

NEWS

PA Farm Link Academy Available

PA Farm Link is pleased to announce their newest educational tool available to the public for free: The PA Farm Link Academy. The PA Farm Link Academy currently includes 8 learning modules that cover the following topics:

- 4 P's of Finance
- Understanding Ag Leasing
- PA Farm Link Overview (English & Spanish Options Available)
- Starting a Food Business
- New Farmer Programs through USDA Grants & the PA Preferred Program
- Business Planning

Each learning module contains a set of lessons, which include an informational video and a 3- question quiz to test your knowledge on the information shared in each lesson. When all lessons are completed within a learning module, a certificate of completion is provided to the participant.

The creation of the PA Farm Link Academy was made possible through the collaboration of the following organizations:

- Natural Resources Conservation Service
- PA Bank & Securities
- PA Dept. of Agriculture
- Penn State Extension
- Penn State Law Center for Ag & Shale Law
- Risk Management Agency
- Rural Development

Small Business Development Center
United States Department of Agriculture

All 8 learning modules can be accessed at pafarmlink.org/academy. For questions or concerns, please contact us at 717-

Bringing You The Best In Greenhouse and Produce Supplies!

Call:
717-532-5918
888-381-8641

Visit:
627 Britton Rd
Shippensburg, Pa 17257

- Greenhouses
- Heaters & Fans
- Irrigation
- Pots & Planters
- Seeds
- Fertilizers



Visit Us Online:
MartinsProduceSupplies.com

**Produce Growing Supplies
Early Order Discounts
Starting Dec. 11th 2023
Through Jan. 12th 2024**

Stocking irrigation supplies in 1/2", 3/4", 1", 1 1/2", 2", and 3".

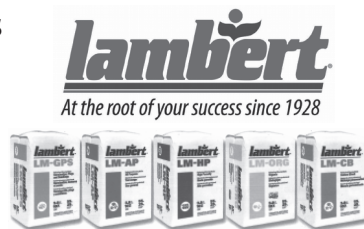

lambert
At the root of your success since 1928



Titan FRP
Tomato Stakes

Heavy Duty
1" round x72"

Call for free catalog.
Too many items to list



BLACK GOLD

PLASTIC MULCH
Black
Clear
Black/White
Metalized
Also
BIODEGRADABLE



NEW Fertilizer

TECHNIGRO
Water-Soluble Fertilizers

AgroThrive
ORGANIC BIO-FERTILIZERS

Gristmill Farm

201 Gristmill Rd.
New Holland PA 17557
Ph. 717-354-8443



**Greenhouse & high tunnel
plastic cut to the length you need!!
10' to 54' widths in stock.**



Clear - IR - 6mil - 4 mil - Blk/Wht - 70%White & Diffused High Tunnel Films

PVGA Membership and Mid-Atlantic Fruit & Vegetable Convention Registration Form

Name _____
 Farm Name _____
 Address _____
 City/State _____ Zip Code _____
 PA County _____ Telephone _____ / _____ / _____ Cell Phone _____ / _____ / _____
 Electronic Mail _____

Check here if you have never been a member of PVGA previously.

Business Information Please check all that apply.
 Grower (owner-operator) Retail Wholesale
 Fresh Market Vegetables Processing Vegetables Greenhouse Vegetables Potatoes
 Small Fruit Bedding Plants Cut Flowers Tree Fruit Wine Grapes
 Grower Employee Supplier (equipment, chemicals, etc.) Processor Other _____

2024 PVGA Membership Dues

Regular Membership Dues increase to \$75 after February 5. \$70.00 _____

Open to all owner, operators and employees of vegetable, potato and berry farm operations, processing firms and supply companies. All memberships include newsletter subscription.

Associate Regular Membership Includes newsletter subscription. \$40.00 _____

Must be one of the following - circle one: Student Retired University Staff Extension Agt.

Keystone Membership An optional membership category open to vegetable and berry farming operations, processing firms, and supplier firms. Includes newsletter subscription.

Dues based on gross income from vegetable potato or berry industries. Any member paying \$75 or more in dues will be considered a Keystone Member. The following rates are only suggestions.

\$100 for up to \$75,000 \$125 for \$75,000 to \$150,000 \$175 for \$150,000 to \$225,000
 \$225 for \$225,000 to \$500,000 \$300 for \$500,000 to \$1,000,000 \$3400 for over \$1,000,000

Associate Keystone Membership Must be a family member or employee of a Keystone Member. \$40.00 _____

2024 Mid-Atlantic Fruit and Vegetable Convention

REGISTRATION IS REQUIRED FOR EACH PERSON, including spouses. Registration fees allow one to attend both fruit and vegetable sessions as well as enter the exhibit area. Each registrant also receives a copy of the Proceedings. Students and children 16 and under receive free registration. No refunds of pre-registration fees will be made unless canceled by January 24 in writing, by phone (717-694-3596) or by email (pvga@pvga.org). No confirmation will be mailed prior to the Convention.

PLEASE LIST THE NAME OF EACH PERSON ATTENDING

(for use in preparing nametags – Circle those attending the Urban Ag session, check those attending Spanish session.)

Member Registration one fee whether you are attending for 1, 2 or 3 days - per person

Advance for the first person from a family, farm or business (\$95 after Jan. 19) @ \$80.00 _____

Advance for additional persons from a family, farm or business (\$95 after Jan 19) @ \$65.00 _____

Non - Member Registration - (family and employees of PVGA members will be admitted at the above member's rates.)

One Day per person @ \$130.00 _____

Three Day includes registration for 2 or 3 days per person. @ \$170.00 _____

Student /Children Registration for students and children 16 and under only @ no charge

Workshops/Tour **PRE-REGISTRATION IS REQUIRED FOR THESE EVENTS** *please indicate who will be attending below*

Producing Vegetable Transplants – Jan 29 (with lunch) *names* _____ @ \$70.00 _____

FSMA Grower Training - Jan. 29 (with lunch) *names* _____ @ \$50.00 _____

Farm Transition Process – Jan 29 (NO lunch) *names* _____ @ \$25.00 _____

High Tunnel Veg. Production – Jan. 29 (with lunch) *names* _____ @ \$70.00 _____

Recall Readiness – Jan. 29 (with lunch) *names* _____ @ \$75.00 _____

PA Pesticide App Training – Jan 29 (with lunch) *names* _____ @ \$85.00 _____

Maximizing Strawberry Production – Jan. 29 (with lunch) *names* _____ @ \$80.00 _____

Software Solutions – Jan. 29 (NO lunch) _____ @ \$15.00 _____

Farm Market Bus Tour – Jan. 29 (with lunch) *names* _____ @ \$95.00 _____

Specialty Mushrooms – Jan. 29 (NO lunch) *names* _____ @ \$35.00 _____

Meals Annual Growers Dinner – January 30 @ \$35.00 _____

Proceedings Registration includes a **free** copy (\$15 if picked up at the Convention) @ \$20.00 _____

Country Folks Grower -Check here to receive a free monthly subscription to this publication _____

Total Enclosed Payment by check or money order only - make checks payable to "PVGA" _____



CLASSIFIEDS

Introducing "Growers Classified"

PVGA is pleased to announce a new, free service to vegetable, potato and berry growers. Classified ads for used equipment or surplus supplies will be published at NO cost in a Growers Classified service.

The ads will be published online on the PVGA website at pvga.org/classified, weekly in the PVGA Update email, and in the Pennsylvania Vegetable Growers News print newsletter.

Ads will be restricted to equipment or supplies specific to vegetable, potato and berry production, not general farm equipment. Other such free classified sections are available in publications like Lancaster Farming but this is designed to focus specifically on items of interest to our growers. Businesses that commercially sell equipment or supplies will not be able to advertise for free.

While classified ads in the PVGA newsletter and email update have always been free to members, this new service will be free to any grower to place an ad. Of course, only PVGA receive the PVG News and the PVGA Update email regularly but the website version will be freely available to anyone with internet access. To place an ad in the Growers Classified, mail your ad to PVGA, 908 North Second St., Harrisburg, PA 17110, fax it to 717-236-2046, or email it to pvga@pvga.org.

Supplies

DANIEL'S FARM STORE LLC

Produce Chemicals and Biologicals

Check out our selection of Convention and Organic/Biopesticides. Also stocking Pesticides for Greenhouse Produce Production. We are a Distributor for Non-Import Beneficial Insects - the New Tool for Insect Pest Resistance.

Call for Pricing - 717-656-6982

Equipment

FOR SALE - Automatic Potato Weigher and Bagger - Paper and poly. Call 610-996-1403 for more info

FOR SALE - Eco Weeder - \$2,400 Call 570-546-5861

FOR SALE - 6" Caprari Irrigation Pump 4 Cycle Turbo Diesel on trailer with 150 gallon fuel tank with Ford engine and Murphy switch. \$9,000

Call Ken at 814-442-1706

Employment

POSITION AVAILABLE - Twin Springs Fruit Farm (TSFF) is looking to hire a new **Commercial Greenhouse/Field Vegetable/ Small Fruits Production Manager, or Manager Trainee**. Some experience in greenhouse production preferred. Job responsibilities include day-to-day greenhouse operations, pest management, including IPM beneficial's, nutrient monitoring, ordering of numerous products. TSFF is a family owned farm located 8 miles west of Gettysburg in the small town of Orrtanna. We are a very diverse Farm, whose main focus is on direct marketing. We presently have over 3/4 of an acre of hot houses that we grow in year-round. We also grow about 40 acres of outdoor vegetables and 10 acres of small fruits.

Contact Jesse King at 575-779-0215 and email resume to: kingdagcfs@yahoo.com



**FARMING MADE BETTER
ONE MACHINE AT A TIME**



Your Complete Source for:
 Sprayers • Hedgers • Pruners • Deleafers
 Shredders • Cultivators • And much more!

www.BDiMachinery.com
 (610) 966-2444 • Sales@BDiMachinery.com

Pennsylvania Vegetable Growers Association

908 North Second Street
Harrisburg, PA 17102
717-973-5915
pvga@pvga.org
www.pvga.org

Change Service Requested



PRESORTED STANDARD
U.S. POSTAGE
PAID
HARRISBURG PA
PERMIT NO. 533



OUTSTANDING

SEED COMPANY, LLC®

B R E E D E R | P R O D U C E R

Outstanding Seed is dedicated to innovation and exceptionalism in breeding, production, and sales of stacking pumpkin, specialty pumpkin, jack-o'-lantern, and mini pumpkin hybrids.

Over sixty hybrids are available to meet many different needs. Call today to place an order or request our 2024 Catalog.

**NEW
FOR
2024**



Kettle Corn F1

- Most fruit are covered with large warts.
- Buttery yellow with green stripes and mottling.
- Average fruit weight is 15 to 25 lbs.
- Average maturity is 95 days.
- Strong powdery mildew resistance.

P.O. Box 1584 | Beaver Falls, PA 15010 | 800.385.9254 | www.outstandingseed.com